



Complete Power Solution™

VGDI-10-40K33

■ USER'S MANUAL ■

Concent

Preface	3
Usage.....	3
Users	3
Note.....	3
Safety Precautions	4
Safety Message Definition	4
Warning Label.....	4
Safety Instruction	4
Debug & Operate	5
Maintenance & Replacement	5
Battery Safety.....	6
Disposal.....	7
1 UPS Structure and Introduction.....	8
1.1 UPS structure	8
1.1.1 UPS Configuration.....	8
1.1.2 UPS Outlook.....	8
1.1.3 Details of UPS front and rear views.....	14
1.2 Product Introduction.....	17
1.2.1 UPS System Description.....	17
1.2.2 Operation Mode	17
2 Installation.....	21
2.1 Location	21
2.1.1 Installation Environment.....	21
2.1.2 Site Selection	21
2.1.3 Size and Weight	21
2.2 Unloading and Unpacking.....	22
2.2.1 Moving and Unpacking of the Cabinet.....	22
2.3 Positioning	24
2.3.1 Positioning Cabinet.....	24
2.4 Battery.....	26
2.5 Cable Entry	27
2.6 Power Cables.....	28
2.6.1 Specifications.....	28
2.6.2 Specifications for Power Cables Terminal	29
2.6.3 Circuit Breaker.....	29
2.6.4 Connecting Power Cables	30
2.7 Control and Communication Cables	32
2.7.1 Dry Contact Interface.....	32
2.7.2 Communication Interface.....	39
3 Control and LCD display Panel.....	40
3.1 LCD Indicator	40
3.2 EPO Button	40
3.3 LCD Touch Screen	40
3.4 Main Menu	41
4 Operations	50
4.1 UPS start-up	50
4.1.1 Startup in normal mode.....	50
4.1.2 Start from battery.....	52
4.2 UPS Shut down	53
4.3 Procedure for Switching between Operation Modes.....	54
4.3.1 Switching the UPS from normal mode into battery mode	54
4.3.2 Switching the UPS from normal mode into bypass mode	54
4.3.3 Switching the UPS into normal mode from bypass mode	54
4.3.4 Switching the UPS into maintenance bypass mode from normal mode	54
4.3.5 Switching the UPS into normal mode from maintenance bypass mode	55

4.4 Battery Maintenance	55
4.5 EPO	56
4.6 Installation of parallel operation system	56
5 Maintenance	58
5.1 Precautions	58
5.2 Instruction for maintaining UPS	58
5.3. Instruction for Maintaining Battery String	58
6 Product Specifications	60
6.1 Applicable Standards.....	60
6.2 Environmental Characteristics	60
6.3 Mechanical Characteristics	61
6.4 Electrical Characteristics.....	61
6.4.1 Electrical Characteristics (Input Rectifier).....	61
6.4.2 Electrical Characteristics (Intermediate DC Link).....	61
6.4.3 Electrical Characteristics (Inverter Output)	62
6.4.4 Electrical Characteristics (Bypass Mains Input).....	62
6.5 Efficiency	63
6.6 Display and Interface	63
Annex. A Installation of internal batteries.....	63

Preface

Usage

The manual contains information on installation, use, operation and maintenance of UPS. Please carefully read this manual prior to installation.

Users

Authorized Person

Note

Our company is providing a full range of technical support and service. Customers can contact our local office or customer service center for help.

The manual will update irregularly, due to the product upgrading or other reasons.

Unless otherwise agreed, the manual is only used as guide for users and any statements or information contained in this manual make no warranty expressed or implied.

Safety Precautions

This manual contains information concerning the installation and operation of UPS. Please carefully read this manual prior to installation.

The UPS cannot be put into operation until it is commissioned by engineers approved by the manufacturer (or its agent). Not doing so could result in personnel safety risk, equipment malfunction and invalidation of warranty.

Safety Message Definition

Danger: Serious human injury or even death may be caused, if this requirement is ignored.



Warning: Human injury or equipment damage may be caused, if this requirement is ignored.

Attention: Equipment damage, loss of data or poor performance may be caused, if this requirement is ignored.



Commissioning Engineer: The engineer who installs or operates the equipment should be well trained in electricity and safety, and familiar with the operation, debug, and maintenance of the equipment.



Warning Label

The warning label indicates the possibility of human injury or equipment damage, and advised the proper step to avoid the danger. In this manual, there are three types of warning labels as below.



Labels	Description
 Danger	Serious human injury or even death may be caused, if this requirement is ignored.
 Warning	Human injury or equipment damage may be caused, if this requirement is ignored.
 Attention	Equipment damage, loss of data or poor performance may be caused, if this requirement is ignored.

Safety Instruction



 Danger	<ul style="list-style-type: none">◇ Performed only by commissioning engineers.◇ This UPS is designed for commercial and industrial applications only, and is not intended for any use in life-support devices or system.
 Warning	<ul style="list-style-type: none">◇ Read all the warning labels carefully before operation, and follow the instructions.

	<ul style="list-style-type: none"> ◇ When the system is running , do not touch the surface with this label, to avoid any hurt of scald.
	<ul style="list-style-type: none"> ◇ ESD sensitive components inside the UPS, anti-ESD measure should be taken before handling.

Move & Installation

 Danger	<ul style="list-style-type: none"> ◇ Keep the equipment away from heat source or air outlets. ◇ In case of fire, use dry powder extinguisher only, any liquid extinguisher can result in electric shock.
 Warning	<ul style="list-style-type: none"> ◇ Don't start the system if any damage or abnormal parts founded. ◇ Contacting the UPS with wet material or hands may be subject to electric shock.
 Attention	<ul style="list-style-type: none"> ◇ Use proper facilities to handle and install the UPS. Shielding shoes, protective clithes and other protective facilities are necessary to aviod injury. ◇ During positioning, keep the UPS way from shock or vibration. ◇ Install the UPS in proper environment, more detail in section 2.3.

Debug & Operate

 Danger	<ul style="list-style-type: none"> ◇ Make sure the grounding cable is well connected before connecting the power cables, the grounding cable and neutral cable must be in accordance with the local and national codes practice. ◇ Before moving or re-connecting the cables, make sure to cut off all the input power sources, and wait for at least 10 minutes for internal discharge. Use a multi-meter to measure the voltage on terminals and ensure the voltage is lower than 36V before operation.
 Attention	<ul style="list-style-type: none"> ◇ The earth leakage current of load will be carried by RCCB OR RCD. ◇ Initial check and inspection should be performed after long time storing of UPS.

Maintenance & Replacement

 Danger	<ul style="list-style-type: none"> ◇ All the equipment maintenance and servicing procedures involving internal access need special tools and should be carried out only by trained personnel. The components that can be accessed by opening the protective cover with tools cannot be maintenance by user. ◇ This UPS full complies with “IEC62040-1-1-General and safety requirements for use in operator access area UPS”. Dangerous
---	---

	<p>voltages are present within the battery box.</p> <p>However, the risk of contact with these high voltages is minimized for non-service personnel. Since the component with dangerous voltage can only be touched by opening the protective cover with a tool, the possibility of touching high voltage component is minimized. No risk exists to any personnel when operating the equipment in the normal manner, following the recommended operating procedures in this manual.</p>
--	---

Battery Safety

 <p>Danger</p>	<ul style="list-style-type: none"> ✧ All the battery maintenance and servicing procedures involving internal access need special tools or keys and should be carried out only by trained personnel. ✧ When connected together, the battery terminal voltage will exceed 400Vdc and is potentially lethal. ✧ Battery manufacturers supply details of the necessary precautions to be observed when working on, or in the vicinity of a large bank of battery cells. These precautions should be followed implicitly at all times. Particular attention should be paid to the recommendations concerning local environmental conditions and the provision of protective clothing, first aid and fire-fighting facilities. ✧ Ambient temperature is a major factor in determining the battery capacity and life. The nominal operating temperature of battery is 20°C. Operating above this temperature will reduce the battery life. Periodically change the battery according to the battery user manuals to ensure the back-up time of UPS. ✧ Replace the batteries only with the same type and the same number, or it may cause explosion or poor performance. ✧ When connecting the battery, follow the precautions for high-voltage operation before accepting and using the battery, check the appearance of the batteries. If the package is damaged, or the battery terminal is dirty, corroded or rusted or the shell is broken, deformed or has leakage, replace it with new product. Otherwise, battery capacity reduction, electric leakage or fire may be caused. ✧ Before operating the battery, remove the finger ring, watch, necklace, bracelet and any other metal jewelry. ✧ Wear rubber gloves. ✧ Eye protection should be worn to prevent injury from accidental electrical arcs. ✧ Only use tools (e.g. wrench) with insulated handles.
--	---

	<ul style="list-style-type: none"> ✧ The batteries are very heavy. Please handle and lift the battery with proper method to prevent any human injury or damage to the battery terminal. ✧ Don't decompose, modify or damage the battery. Otherwise, battery short circuit, leakage or even human injury may be caused. ✧ The battery contains sulfuric acid. In normal operation, all the sulfuric acid is attached to the separation board and plate in the battery. However, when the battery case is broken, the acid will leak from the battery. Therefore, be sure to wear a pair of protective glasses, rubber gloves and skirt when operating the battery. Otherwise, you may become blind if acid enters your eyes and your skin may be damaged by the acid. ✧ At the end of battery life, the battery may have internal short circuit, drain of electrolytic and erosion of positive/negative plates. If this condition continues, the battery may have temperature out of control, swell or leak. Be sure to replace the battery before these phenomena happen. ✧ If a battery leaks electrolyte, or is otherwise physically damaged, it must be replaced, stored in a container resistant to sulfuric acid and disposed of in accordance with local regulations. ✧ If electrolyte comes into contact with the skin, the affected area should be washed immediately with water.
--	---

Disposal

 Warning	<ul style="list-style-type: none"> ✧ Dispose of used battery according to the local instructions.
--	--

1 UPS Structure and Introduction

1.1 UPS structure

1.1.1 UPS Configuration

The UPS configurations are provided in Table 1-1.

Table 1-1 UPS Configuration

Item	Components	Quantity	Remark
VGDII-10-40K33	Circuit Breakers	5	Standard
	Dual Input	1	Standard
	Parallel Card	1	Optional
	Dry Contact Card	1	Optional
VGDII-10-40K33XL	Circuit Breakers	4	Standard
	Dual Input	1	Standard
	Parallel Card	1	Optional
	Dry Contact Card	1	Optional

1.1.2 UPS Outlook

The UPS outlooks are shown as figure 1-1.

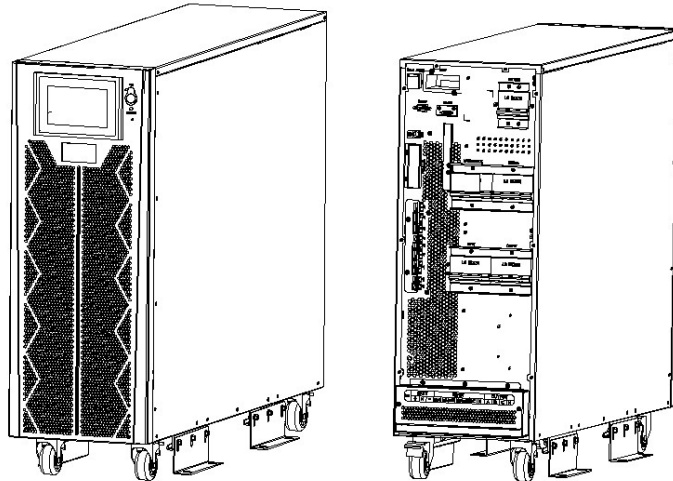

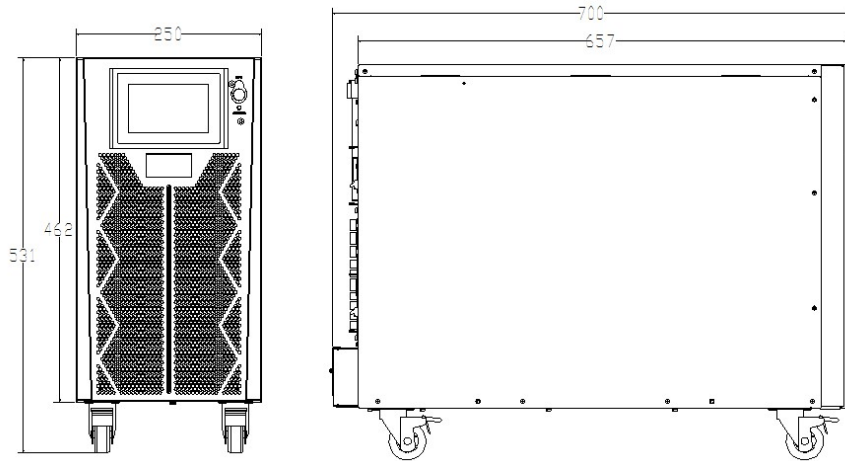

(a) Outlook of VGDII-10-15K33XL (unit: mm)

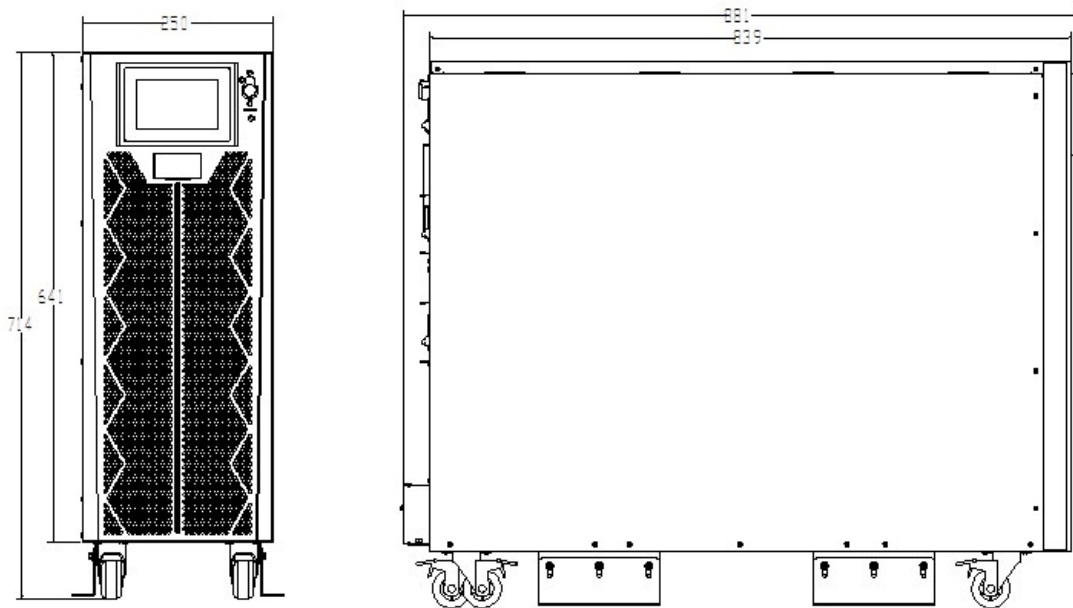
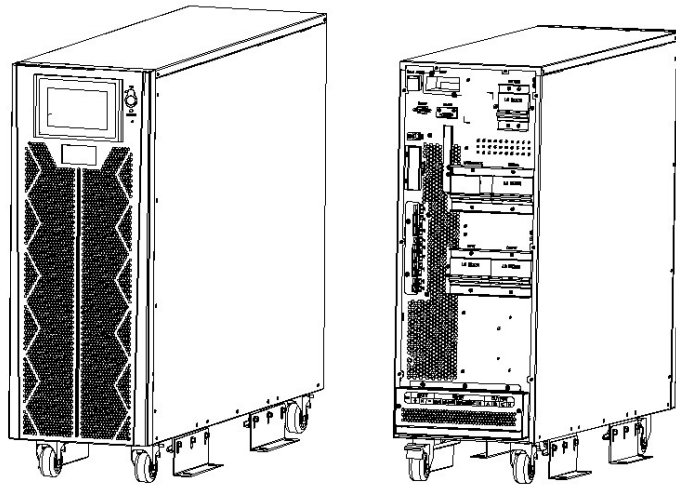

(b) Outlook of VGDII-10-15K33 (unit: mm)

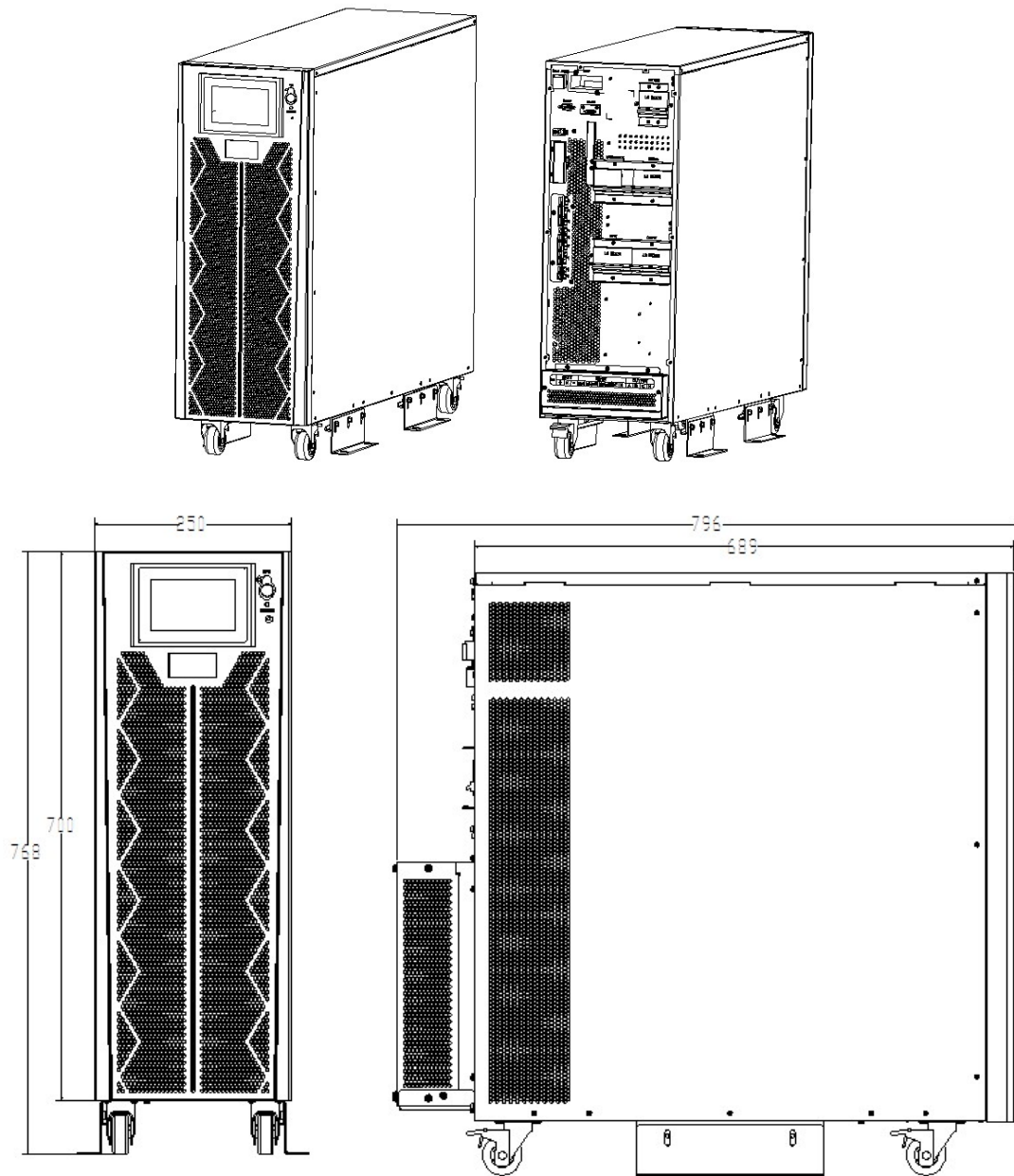

(c) Outlook of VGDII-20-30K33XL (unit: mm)

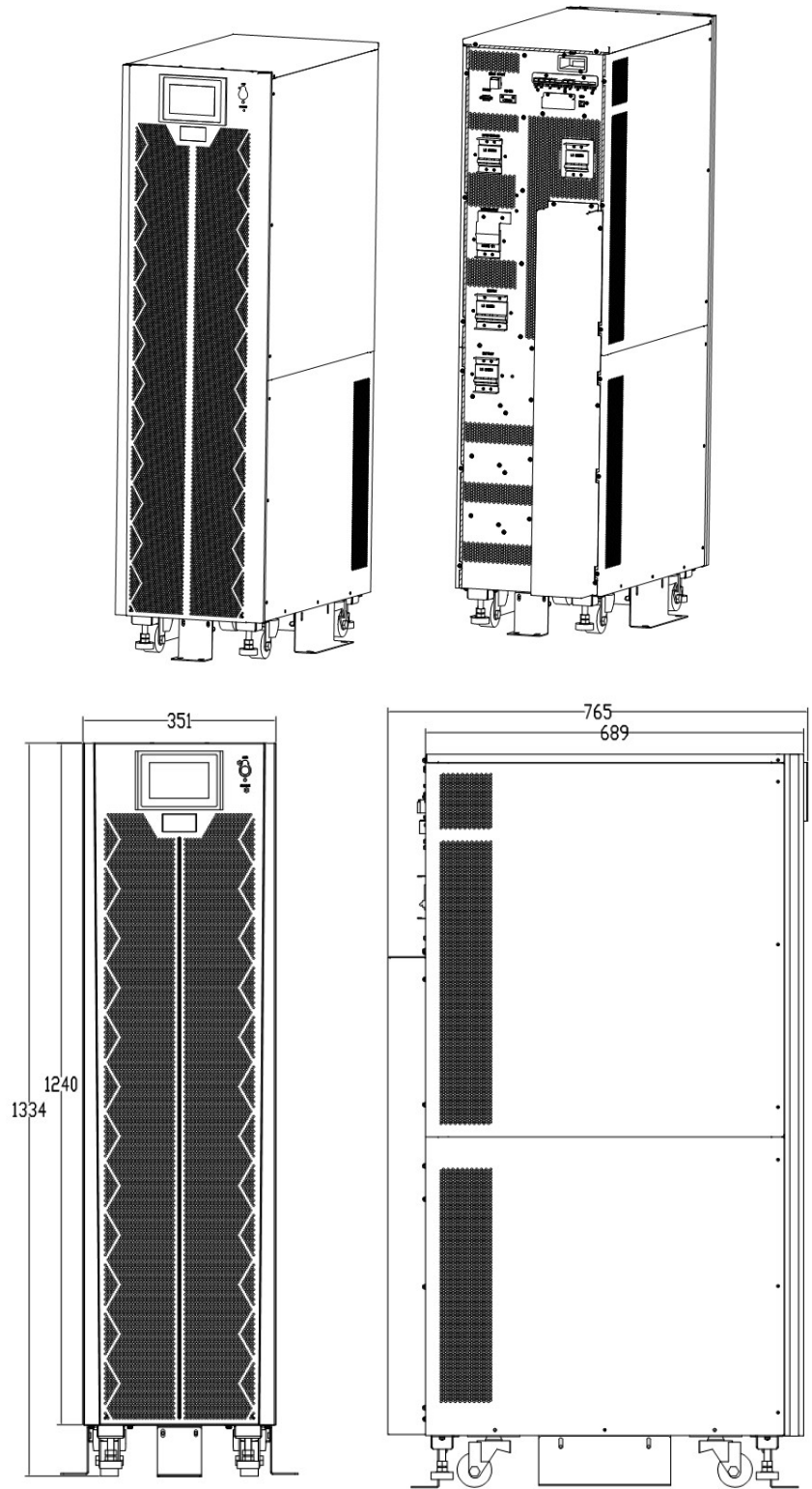

(d) Outlook of VGDII-20-30K33 (unit: mm)

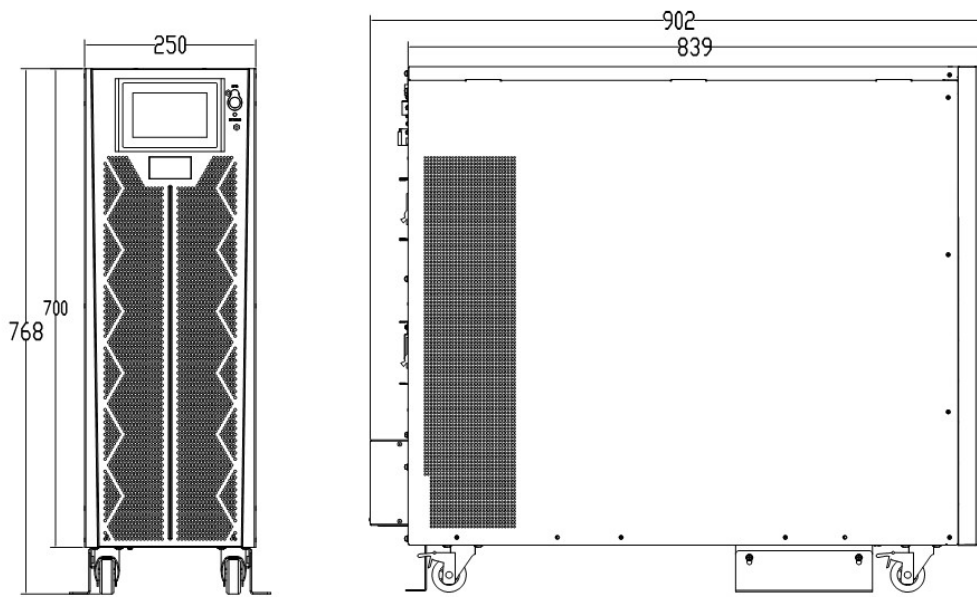
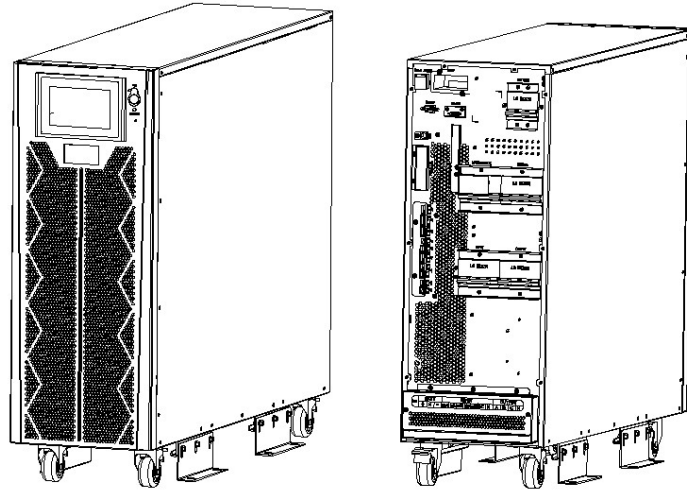

(e) Outlook of VGDII-40K33XL (unit: mm)

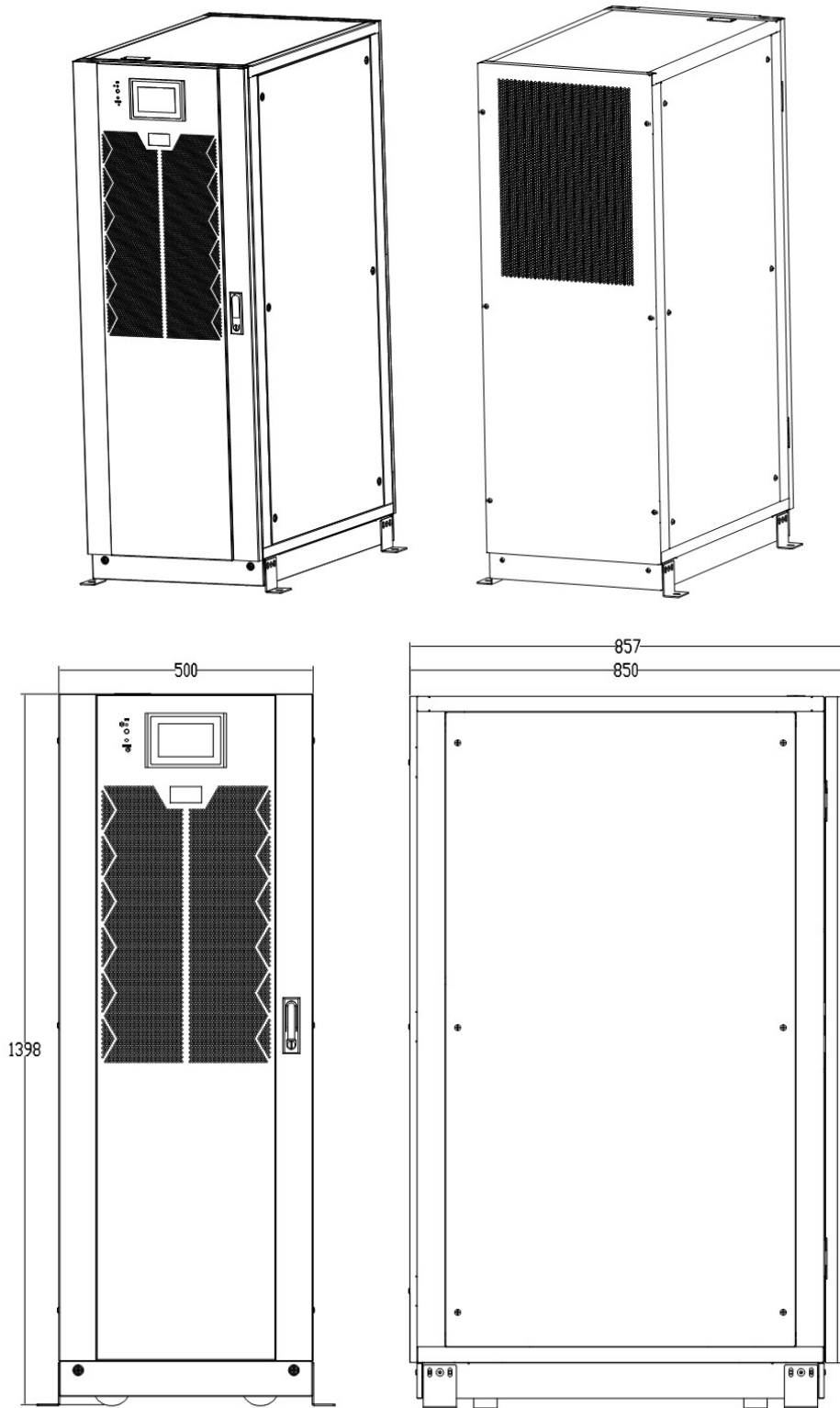

(f) Outlook of VGDII-40K33 (unit: mm)

Figure 1-1 UPS Outlook

1.1.3 Details of UPS front and rear views

The UPS front and rear views are shown as Figure 1-2.

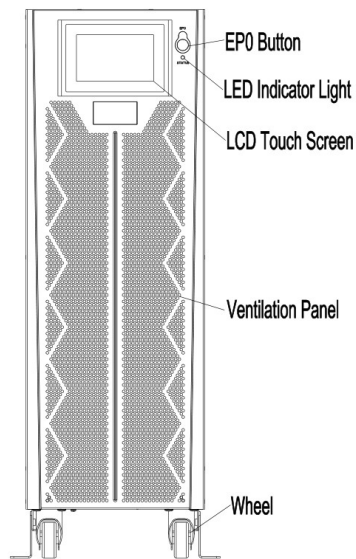

(a) Details of front view for VGDII-10-40K33XL and VGDII-10-30K33XL

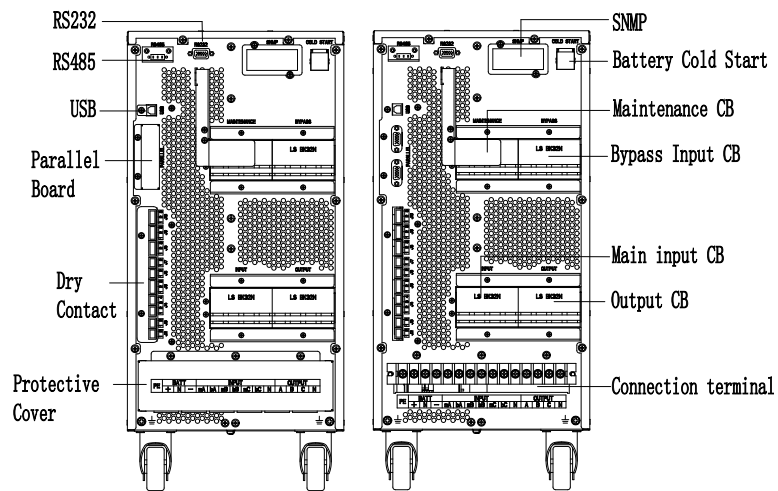

(b) Details of rear view for VGDII-10-15K33XL

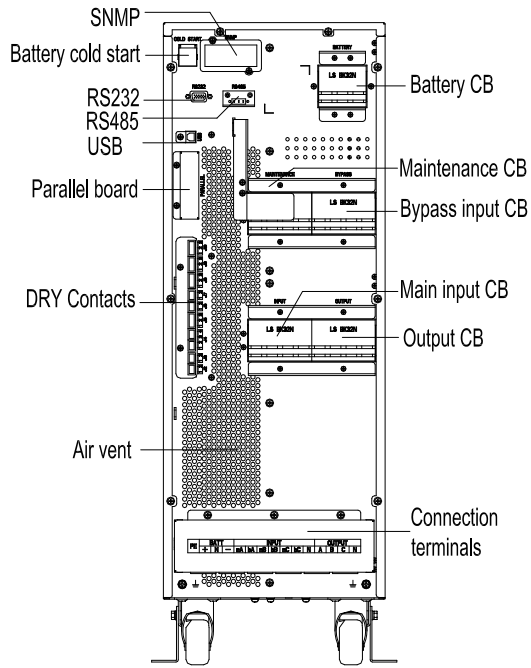

(c) Details of rear view for VGDII-10-15K33

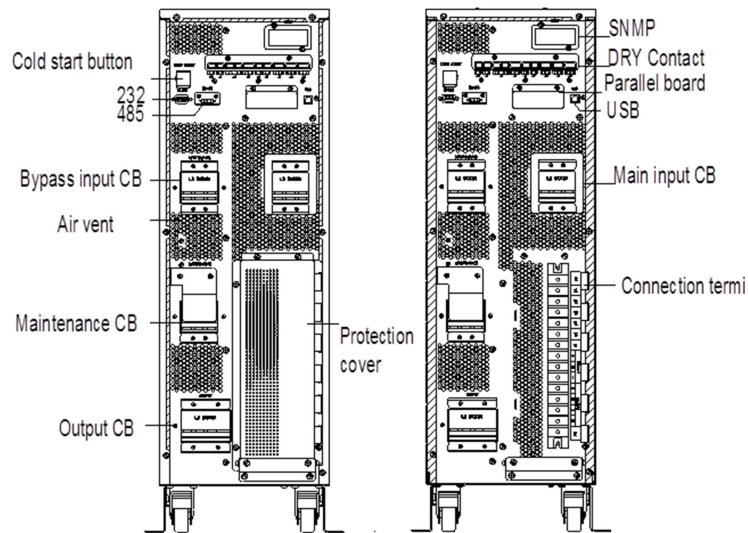

(d) Details of rear view for 20kVA and 30kVA long backup type

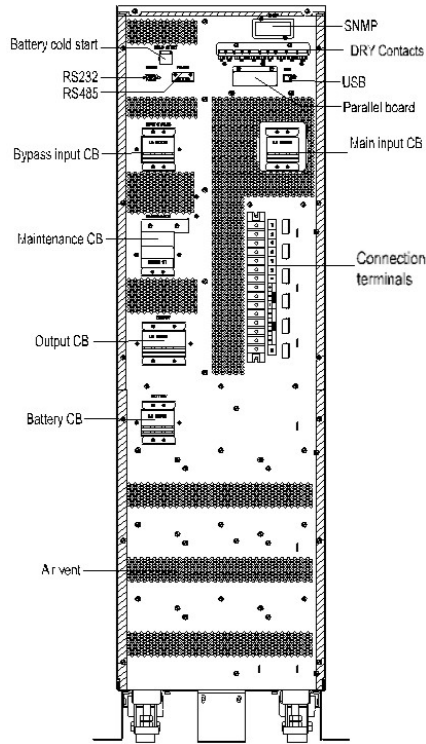

(e) Details of rear view for 20kVA and 30kVA standard type

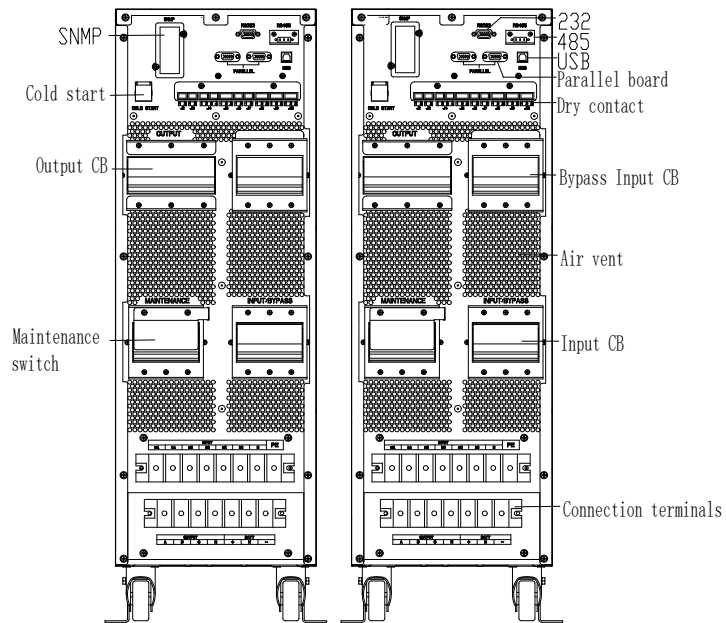

(f) Details of rear view for 40Kva long backup type

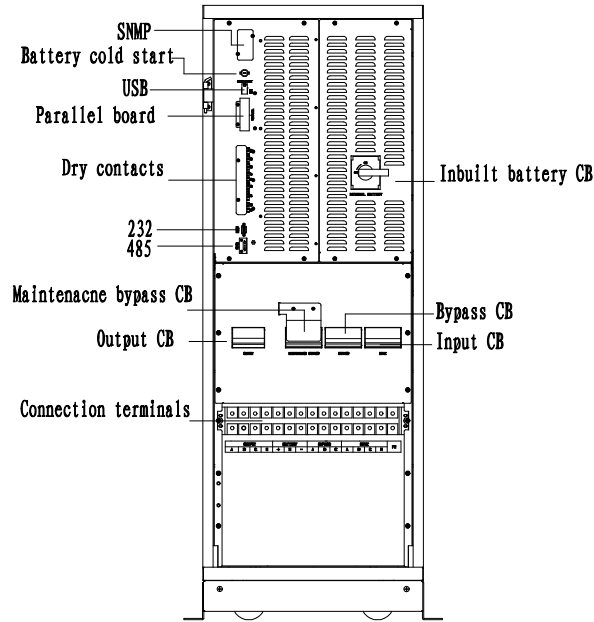

(g) Details of rear view for 40kVA standard backup type
Figure 1-2 Details of UPS front and rear views

1.2 Product Introduction

1.2.1 UPS System Description

The tower UPS is configured by the following part: rectifier, charger, inverter, static bypass switch and Maintenance bypass breaker. One or several battery strings should be installed to provide backup energy once the utility fails. The UPS structures are shown in Figure 1-3.

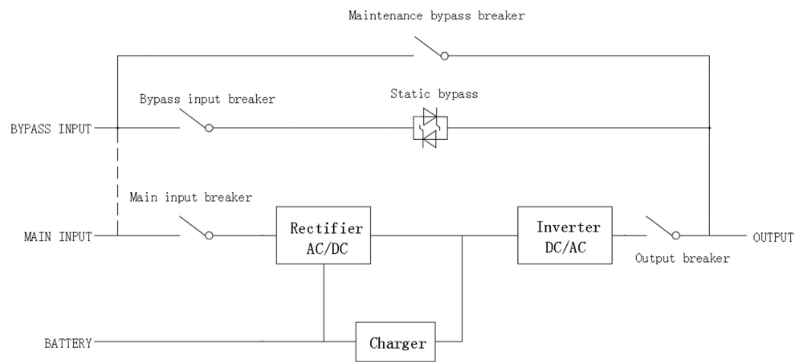

Figure 1-3 UPS Block Diagram

1.2.2 Operation Mode

The tower UPS is an on-line, double-conversion UPS that permits operation in the following modes:

- Normal mode

- Battery mode
- Bypass mode
- Maintenance mode(manual bypass)
- ECO mode
- Frequency Converter mode

1.2.2.1 Normal Mode

The inverters continuously supply AC power to the critical AC load. The rectifier derives power from the AC mains input source and supplies DC power to the inverter, meanwhile the charger derives the DC power from the rectifier and charges its associated backup batteries.

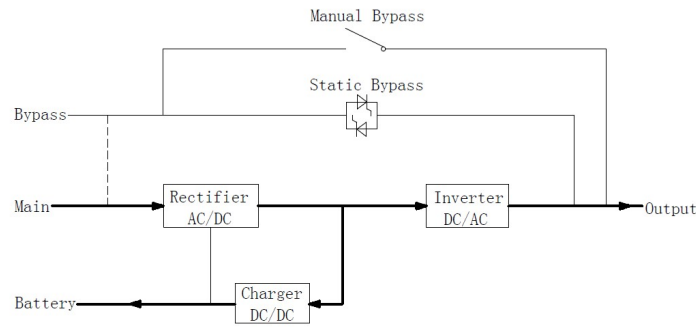

Figure 1-4 Normal mode operation diagram

1.2.2.2 Battery Mode

Upon failure of the AC mains input power, the inverters of power modules will obtain power from the batteries, and supply AC power to the critical AC load. There is no interruption to the critical load. After restoration of the AC mains input power, UPS will transfer automatically to normal mode without users' intervention.

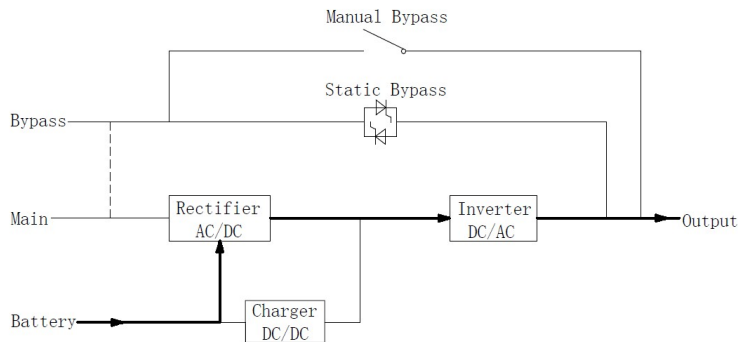

Figure 1-5 Battery Mode operation diagram

Note: With the function of “Battery Cold Start”, the UPS could start without utility. For 2-slot and 4-slot cabinet UPS, “Battery Cold Start” is optional, and for 6-slot and 10-slot cabinet UPS, it’s standard.

1.2.2.3 Bypass Mode

If the inverter overload capacity is exceeded under normal mode, or if the inverter becomes unavailable for any reason, the static switch will perform a transfer of the load from the inverter to the bypass source, without interruption to critical AC load. If the inverter is asynchronous with the bypass source, an interruption would exist in the transfer from the inverter to the bypass. This is to avoid large cross current due to the paralleling of unsynchronized AC sources. This interruption is programmable, but the typically setting is less than 3/4 of an electrical cycle, e.g. less than 15ms (50HZ) or less than 12.5ms (60HZ). The action of transfer/re-transfer can be done by the command through the monitor screen.

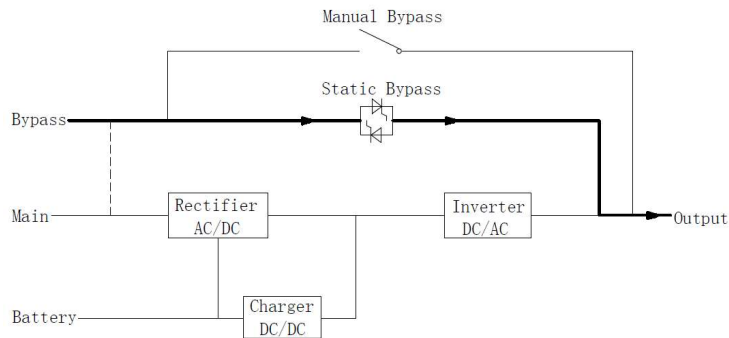

Figure 1-6 Bypass mode operation diagram

1.2.2.4 Maintenance Mode (Manual Bypass)

A manual bypass switch is available to ensure continuity of supply to the critical load when the UPS becomes unavailable e.g. during a maintenance procedure.

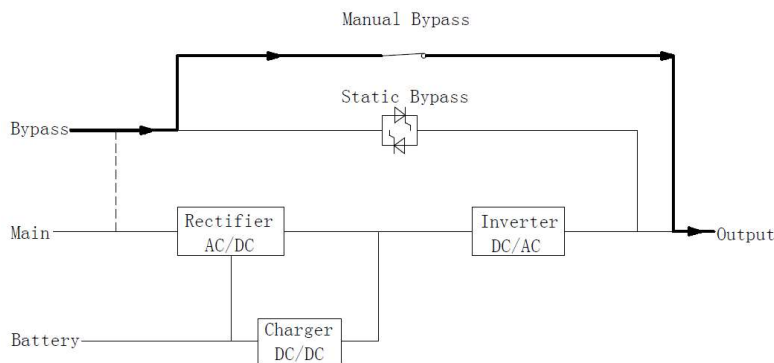

Figure 1-7 Maintenance mode operation diagram



Danger

During Maintenance mode, dangerous voltages are present on the terminal of input, output and neutral, even with all the modules and the LCD turned off.

1.2.2.5 ECO Mode

To improve system efficiency, UPS system works in Bypass Mode at normal time, and the inverter is standby, when the utility from the bypass fails, the UPS will transfer to Battery Mode and the inverter powers the load.

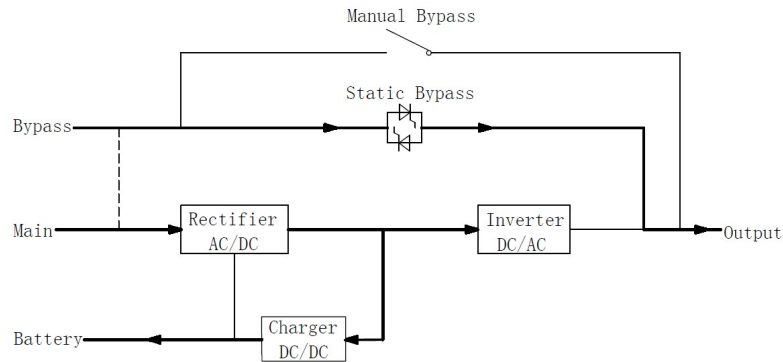

Figure 1-8 ECO Mode operation diagram

Note

There is a short interruption time (less than 10ms) when transferring from ECO mode to battery mode, it must be sure that the interruption has no effect on loads.

1.2.2.6 Frequency Converter Mode

By setting the UPS to “Frequency Converter Mode”, the UPS could present a stable output of fixed frequency (50 or 60HZ), and the bypass static switch is not available.

2 Installation

2.1 Location

As each site has its own requirements, the installation instructions in this section are as a guide for the general procedures and practices that should be observed by the installing engineer.

2.1.1 Installation Environment

The UPS is intended for indoor installation and uses forced convection cooling by internal fans. Please make sure there is enough space for the UPS ventilation and cooling.

Keep the UPS far away from water, heat and inflammable and explosive corrosive material. Avoid installing the UPS in the environment with direct sunlight, dust, volatile gases, corrosive material and high salinity.

Avoid installing the UPS in the environment with conductive dirt.

The operating environment temperature for batteries is 20°C-25°C. Operating above 25°C will reduce the battery life, and operation below 20°C will reduce the battery capacity.

The battery will generate a little amount of hydrogen and oxygen at the end of charging; ensure the fresh air volume of the battery installation environment must meet EN50272-2001 requirements.

When external batteries are used, the battery circuit breakers (or fuses) must be mounted as close as possible to the batteries, and the connecting cables should be as short as possible.

2.1.2 Site Selection

Ensure the ground or installation platform can bear the weight of the UPS cabinet, batteries and battery racks.

No vibration and less than 5 degree inclination horizontally.

The equipment should be stored in a room so as to protect it against excessive humidity and heat sources.

The battery needs to be stored in dry and cool place with good ventilation. The most suitable storage temperature is 20°C to 25°C.

2.1.3 Size and Weight

Ensure there is enough space for the placement of the UPS. The room reserved for the UPS cabinet is shown in Figure 2-1.



Attention

Ensure there is at least 0.8m before the front of the cabinet so as to easily maintain the power module and at least 0.5m behind for ventilation and cooling. The room reserved for the cabinet is shown in Figure2-1.

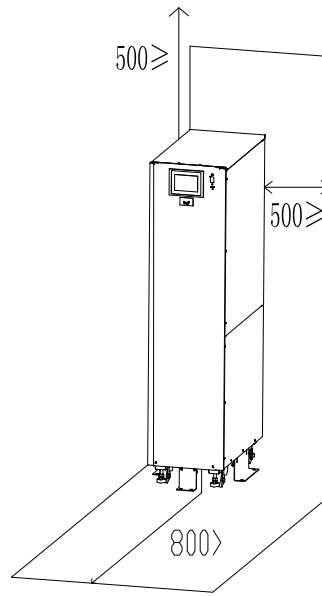

Figure 2-1 Space reserved for the cabinet (Unit: mm)

The dimension and weigh for the UPS cabinet is shown in Table 2-1

Table 1.1 Weight for the cabinet

Configuration	Dimension(W*D*H)mm	Weight
VGDII-10-15K33	250*880*715	51.5kg(No Batteries Included)
VGDII-10-15KXL	250*700*530	31kg
VGDII-20-30K33	350*765*1335	89kg(No Batteries Included)
VGDII-20-30K33XL	250*800*770	52kg
VGDII-40K33XL	250*900*770	61kg
VGDII-40K33	500*860*1400	140kg

2.2 Unloading and Unpacking

2.2.1 Moving and Unpacking of the Cabinet

The steps to move and unpack the cabinet are as follows:

1. Check if any damages to the packing. (If any, contact to the carrier)

2. Transport the equipment to the designated site by forklift, as shown in Figure2-2.

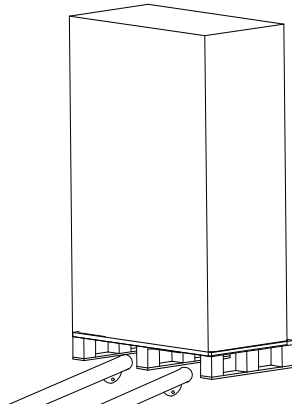

Figure 2-2 Transport to the designated site

3. Unpack the package as shown in Figure 2-3.

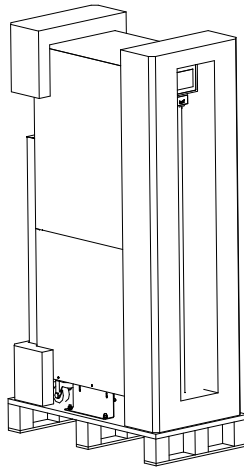

Figure 2-3 Disassemble the case

4. Remove the protective foam around the cabinet as shown in Figure 2-4.

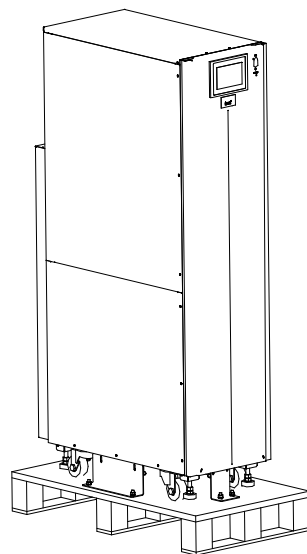

Figure 2-4 remove the protective foam

5. Check the UPS.

- (a) Visually examine if there are any damages to UPS during transportation. If any, contact to the carrier.
- (b) Check the UPS with the list of the goods. If any items are not included in the list, contact to our company or the local office.
6. Dismantle the bolt that connects the cabinet and wooden pallet after disassembly.
7. Move the cabinet to the installation position.
-



Attention

Be careful while removing to avoid scratching the equipment.



Attention

The waste materials of unpacking should be disposed to meet the demand for environmental protection.

2.3 Positioning

2.3.1 Positioning Cabinet

For VGDII-20-40K33, the UPS cabinet has two way of supporting itself: One is to support itself temporarily by the four wheels at the bottom, making it convenient to adjust the position of the cabinet; The other is by anchor bolts to support the cabinet permanently after adjusting the position of the cabinet. For VGDII-10-40K33XL and VGDII-10-15K33, the UPS cabinet supports itself only by the four wheels at the bottom. The supporting structure is shown in Figure 2-5.

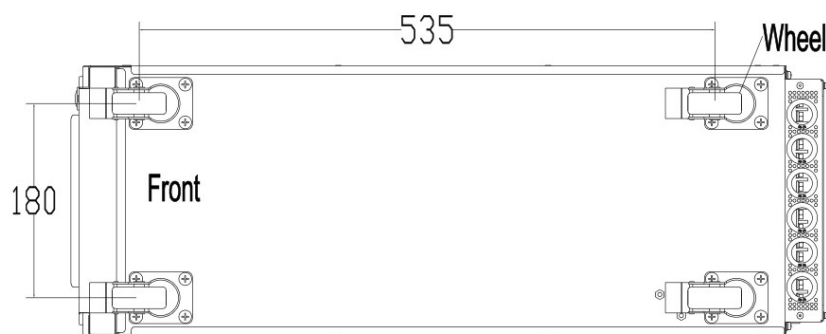

(a) VGDII-10-15K33XL (Bottom, unit: mm)

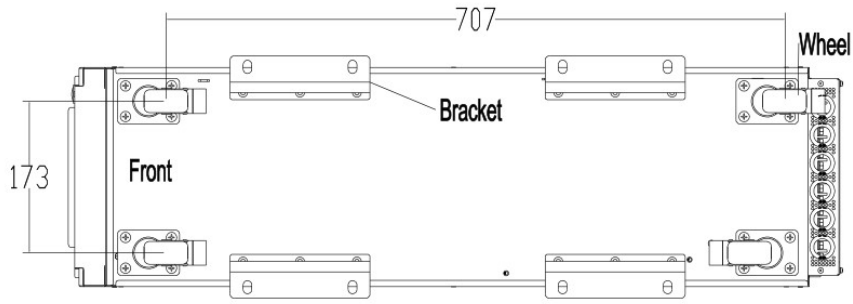

(b) VGDII-10-15K33 (Bottom, unit: mm)

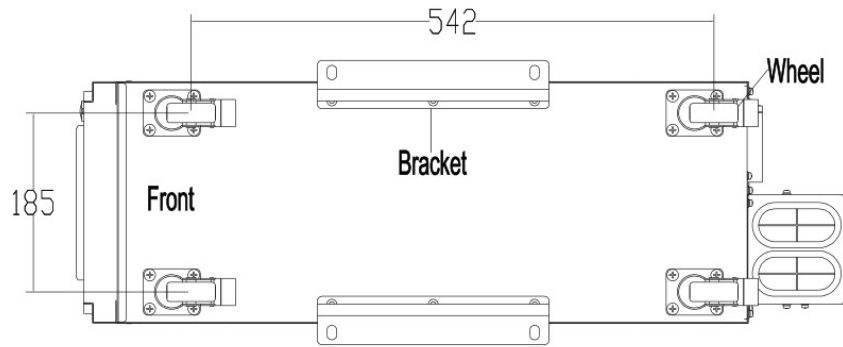

(c) VGDII-20-30K33XL (Bottom, unit: mm)

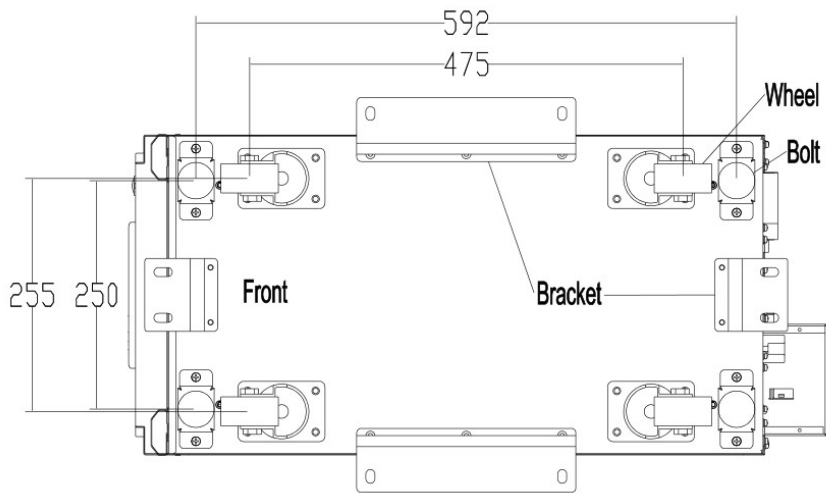

(d) VGDII-20-30K33 (Bottom, unit: mm)

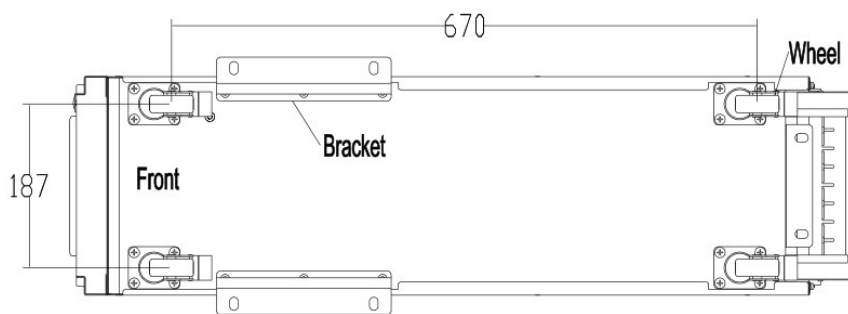

(e) 40kVA long backup type (Bottom, unit: mm)

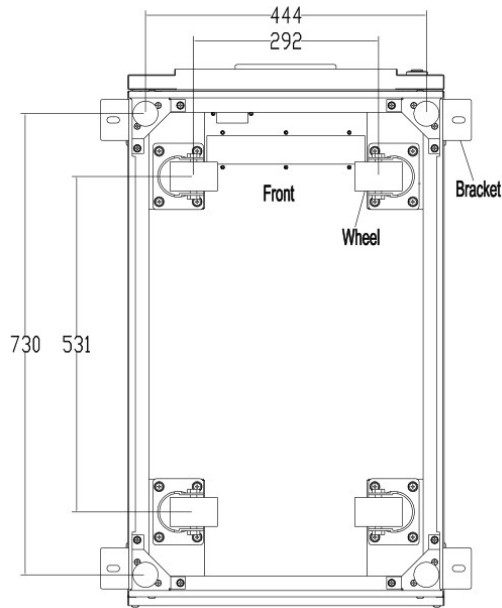

(f) VGDII-40K33 (Bottom, unit: mm)

Figure 2-4 Supporting structure (Bottom View)

The steps to position the cabinet are as follows:

1. Ensure the supporting structure is in good condition and the mounting floor is smooth and strong.
2. Retract the anchor bolts by turning them counter clockwise using wrench, the cabinet is then supported by the four wheels.
3. Adjust the cabinet to the right position by the supporting wheels.
4. Put down the anchor bolts by turning them clockwise using wrench, the cabinet is then supported by the four anchor bolts.
5. Ensure the four anchor bolts are in the same height and the cabinet is fixed and immovable.



Attention

Auxiliary equipment is needed when the mounting floor is not solid enough to support the cabinet, which helps distribute the weight over a larger area. For instance, cover the floor with iron plate or increase the supporting area of the anchor bolts.

2.4 Battery

Three terminals (positive, neutral, negative) are drawn from the battery group and connected to UPS system. The neutral line is draw from the middle of the batteries in series (See Figure 2-5)

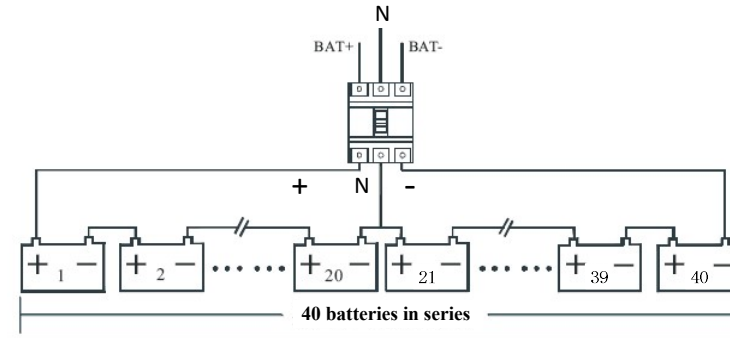

Figure 2-5 Battery connection diagram

! Danger

The battery terminal voltage is of more than 400Vdc, please follow the safety instructions to avoid electric shock hazard.

Ensure the positive, negative, neutral electrode is correctly connected from the battery unit terminals to the breaker and from the breaker to the UPS system.

2.5 Cable Entry

For VGDII-10-15K33 and VGDII-10-15K33XL, cables enter from the bottom of the rear side.

For VGDII-20-30K33 and VGDII-20-30K33XL, cables enter from the right side of the rear side.

For VGDII-40K33 and VGDII-40K33XL, cables enter from the bottom of the rear side.

These cable entry ways are shown in Figure 2-6.

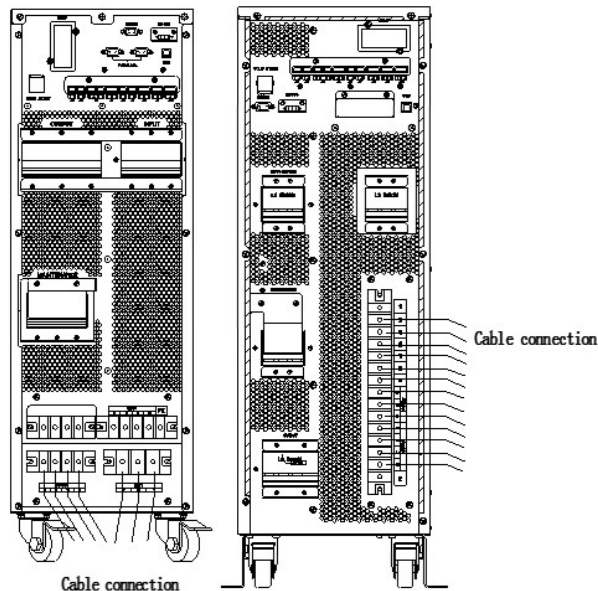

(a) Cables entry from the bottom or the right side of the rear

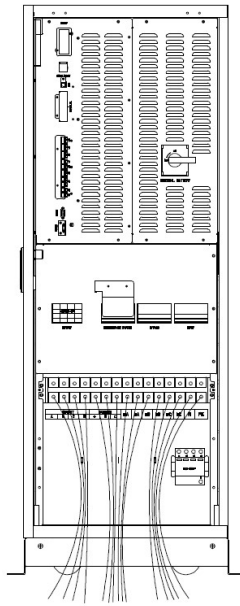

(b) Cables entry from the bottom of the front
Figure 2-6 Cables entry

2.6 Power Cables

2.6.1 Specifications

The UPS power cables are recommended in Table 2-2.

Table 2-2 Recommended sizes for power cables

Contents		VGDII-10-15K	VGDII-20-30K	VGDII-40K	
Main Input	Main Input Current(A)	18/28	35/55	70	
	CableSection (mm ²)	A	6	10	16
		B	6	10	16
		C	6	10	16
		N	6	10	16
Main Output	Main Output Current(A)	15/23	30/45	60	
	CableSection (mm ²)	A	6	10	16
		B	6	10	16
		C	6	10	16
		N	6	10	16
Bypass Input (Optional)	Bypass Input Current(A)	15/23A	30/45A	60A	
	CableSection (mm ²)	A	6	10	16
		B	6	10	16
		C	6	10	16
		N	6	10	16
Battery Input	Battery Input current(A)	20/30A	40/60A	80A	

	CableSection (mm ²)	+	8	16	25
		-	8	16	25
		N	8	16	25
PE	CableSection	PE	6	10	16

 **Note**

The recommended cable section for power cables are only for the situations described below:

- Ambient temperature: +30°C .
- AC loss is less than 3%, DC loss is less than 1%, the length of the AC power cables should be no longer than 50 meters and the length of the DC power cables should be no longer than 30 meters.
- Currents listed in the table are based on the 380V system (line to line voltage). For 400V system, the current is 0.95 times and for the 415V system the current is 0.92 times.
- The size of neutral lines should be 1.5-1.7 times the value listed above when the predominant load is non-linear.

2.6.2 Specifications for Power Cables Terminal

Specifications for power cables connector are listed as Table 2-3.

Table 2-3 Requirements for power terminal

Port	Connection	Bolt	Bolt	Torque
Mains input	Cables crimped OT terminal	M6	7mm	4.9Nm
Bypass Input	Cables crimped OT terminal	M6	7mm	4.9Nm
Battery Input	Cables crimped OT terminal	M6	7mm	4.9Nm
Output	Cables crimped OT terminal	M6	7mm	4.9Nm
PE	Cables crimped OT terminal	M6	7mm	4.9Nm

2.6.3 Circuit Breaker

The external circuit breakers (CB) for the system are recommended in Table 2-4.

Table 2-4 Recommended CB

Installed	VGDII-10K	VGDII-15K	VGDII-20K	VGDII-30K	VGDII-40K
Input CB	32A/3P	40A/3P	63A/3P	100A/3P	100A/3P

Bypass input CB	32A/3P	40A/3P	63A/3P	63A/3P	100A/3P
Output CB	32A/3P	40A/3P	63A/3P	63A/3P	100A/3P
External	32A/3P	40A/3P	63A/3P	63A/3P	100A/3P
Battery CB	32A/3P	40A,250Vdc	63A,250Vdc	100A,250Vdc	125A,250Vdc

 **Attention**

The CB with RCD (Residual Current Device) is not suggested for the system.

2.6.4 Connecting Power Cables

The steps of connecting power cables are as follows:

- 1) Verify that all the external input distribution switches of the UPS are completely open and the UPS internal maintenance bypass switch is open, Attach necessary warning signs to these switches to prevent unauthorized operation.
- 2) For VGDII-10-30K33 and VGDII-10-40K33XL, the connection terminals are in the rear of UPS, for VGDII-40K33, the connection terminals are in the front of UPS, remove the metal protective cover, the terminals are shown in Figure 2-7

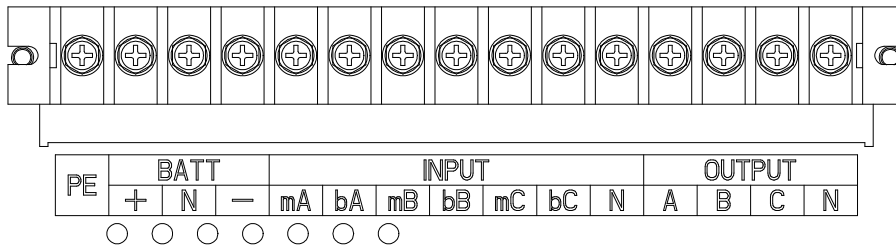

(a) Connection terminals for VGDII-10-15K

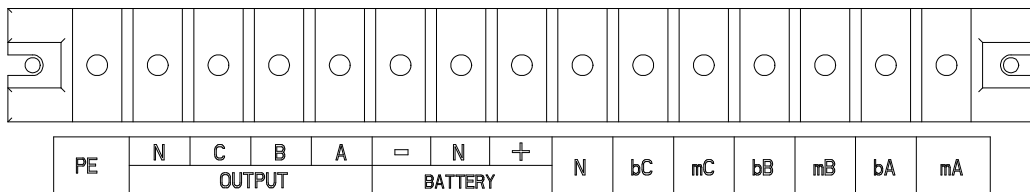

(b) Connection terminals for VGDII-20-30K

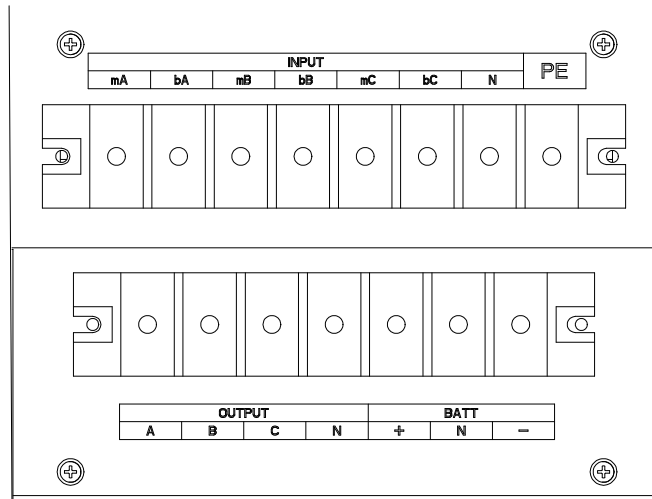

(c) Connection terminals for VGDII-40K33XL

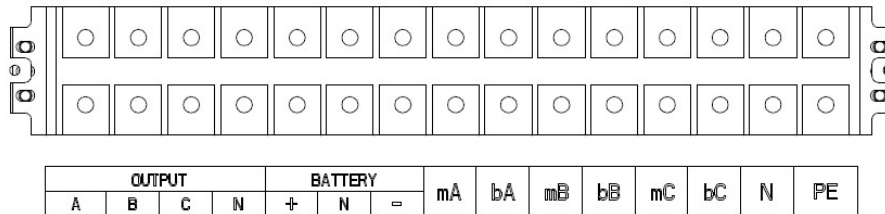

(d) Connection terminals for VGDII-40K33

Figure 2-7 Cable connection terminals

- 3) Connect the protective earth wire to protective earth terminal (PE).
- 4) Connect the AC input supply cables to the main input terminal and AC output supply cables to the output terminal.
- 5) Connect the battery cables to the battery terminal.
- 6) Check to ensure there is no mistake and re-install all the protective covers.

Note: mA, mB, mC standard for Main input phase A, B and C; bA, bB, bC standard for Bypass Input phase A, B and C.

 **Attention**

The operations described in this section must be performed by authorized electricians or qualified technical personnel. If you have any difficulties, contact the manufacturer or agency.

 **Warning**

- Tighten the connections terminals to enough torque moment, refer to Table 2-3, and please ensure correct phase rotation.
- Before connection, ensure the input switch and the power supply are off, attach warnings label to warn not to operate by others
- The grounding cable and neutral cable must be connected in accordance with local and national codes.
- When the cable holes does not goes through by cables, it should be filled by the hole stopper.

2.7 Control and Communication Cables

UPS is configured with RS232 and RS485 interfaces, dry contact, USB and SNMP card are optional, as is shown in Figure 2-8.

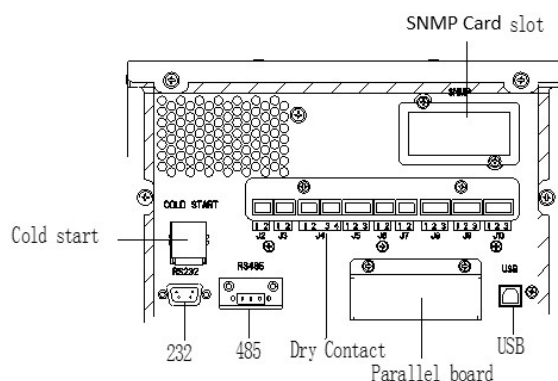

Figure 2-8 Dry contact & communication interface

2.7.1 Dry Contact Interface

The UPS provides the dry contact ports from J2 to J10, and the ports J5, J6-2, J7 can be programmable as input ports, the UPS can accept the dry contact signal from these ports to act some operations. The ports J6-1, J8, J9, and J10 can be programmable as output ports, when the UPS is in some actions, the UPS can send out the dry contact signal to external devices for indicating the status of the UPS or acting. The default definitions of these ports are shown in Table 2-5.

Table 2-5 Default Functions of the ports

Port	Name	Function
J2-1	TEMP_BAT	Detection of battery temperature
J2-2	TEMP_COM	Common terminal for temperature detection
J3-1	ENV_TEMP	Detection of environmental temperature
J3-2	TEMP_COM	Common terminal for temperature detection
J4-1	REMOTE_EPO_NC	Trigger EPO when disconnected with J4-2
J4-2	+24V_DRY	+24V
J4-3	+24V_DRY	+24V
J4-4	REMOTE_EPO_NO	Trigger EPO when short-circuited with J4-3
J5-1	+24V_DRY	+24V
J5-2	GEN_CONNECTED	Input dry contact, the function is settable, Default: interface for the generator
J5-3	GND_DRY	Ground for +24V
J6-1	BCB Drive	Output dry contact, the function is settable. Default: Battery trip signal
J6-2	BCB_Status	Input dry contact, the function is settable.

		Default: BCB Status (Alarm no battery if BCB Status is invalid).
J7-1	GND_DRY	Ground for +24V
J7-2	BCB_Online	Input dry contact, the function is settable. Default: BCB Online (when short-circuited with J7-1, it indicates BCB online, and BCB Status is available).
J8-1	BAT_LOW_ALARM_NC	Output dry contact (Normally closed), the function is settable. Default: Low battery alarm
J8-2	BAT_LOW_ALARM_NO	Output dry contact (Normally open), the function is settable. Default: Low battery alarm
J8-3	BAT_LOW_ALARM_GND	Common terminal for J8-1 and J8-2
J9-1	GENERAL_ALARM_NC	Output dry contact, (Normally closed) the function is settable. Default: Fault alarm
J9-2	GENERAL_ALARM_NO	Output dry contact, (Normally open) the function is settable. Default: Fault alarm
J9-3	GENERAL_ALARM_GND	Common terminal for J9-1 and J9-2
J10-1	UTILITY_FAIL_NC	Output dry contact, (Normally closed) the function is settable. Default: Utility abnormal alarm
J10-2	UTILITY_FAIL_NO	Output dry contact, (Normally open) the function is settable. Default: Utility abnormal alarm
J10-3	UTILITY_FAIL_GND	Common terminal for J10-1 and J10-2

 **Note**

The input dry contact ports J5-2, J6-2, and J7 can be programmed through our MTR software, the programmable events are shown in Table 2-6.

Table 2-6 Input Programmable Events

NO.	Event	Description
1	Generator Input	The input power is supplied by the generator
2	Main CB Close	Main input breaker is closed
3	Mute	Mute
4	BCB Status	BCB status, closed or open
5	Transfer Inverter	UPS would transfer to the inverter mode
6	BCB Online	Enable the BCB status checking
7	Transfer Bypass	UPS would transfer to the bypass mode
8	Fault Clear	Recheck the fault or alarm information
9	Battery Over Charge	Batteries are over charged

10	Battery Over Discharge	Batteries are over discharging
11	Stop Boost Charge	Stop boost charging

Note: The output dry contact ports J6-1, J8, J9 and J10 can be programmed through our MTR software, the programmable events are shown in Table 2-7.

Table 2-7 Output Programmable Events

NO.	Event	Description
1	BCB Trip	BCB tripping
2	Byb Backfeed Trip	Bypass backfeed protective breaker tripping
3	Overload	Output is overload
4	General Alarm	General alarms
5	Output Lost	No output voltage
6	Battery Mode	UPS works in battery mode
7	Utility Fail	The power-grid fails
8	On Inverter	UPS works in inverter mode
9	Battery Charge	Batteries are being charged
10	Normal Mode	UPS works in normal mode
11	Batt Volt Low	Batteries voltage is low
12	On Bypsaa	UPS works in bypass mode
13	Batt Discharge	Batteries are discharging
14	Rectifier Ready	The rectifier is starting
15	Battery Boost Charge	Batteries are boosting charged

Note: There below take the default definitions for example to introduce the methods of application.

Interface of Battery and Environmental Temperature Detection

The input dry contact J2 and J3 can detect the temperature of batteries and environment respectively, which can be used in environment monitoring and battery temperature compensation. Interfaces diagram for J2 and J3 are shown in Figure 2-22, the description of the interface is in Table 2-8.

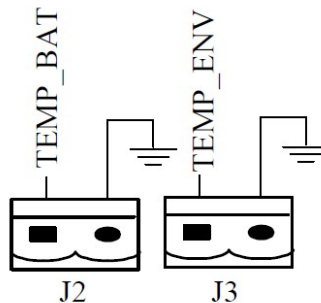

Figure 2-22 J2 and J3 for temperature detecting

Table 2-8 Description of J2 and J3

Port	Name	Function
J2-1	TEMP_BAT	Detection of battery temperature

J2-2	TEMP_COM	common terminal
J3-1	ENV_TEMP	Detection of environmental temperature
J3-2	TEMP_COM	common terminal

 **Note**

A specified temperature sensor is required for temperature detection, and it's optional, please confirm with the manufacturer or the local agency before the order.

Remote EPO Input Port

J4 is the input port for remote EPO. It requires connecting NC (J4-1) and +24V (J4-2) and disconnecting NO (J4-4) and +24V (J4-3) during normal operations, and EPO is triggered when disconnecting NC (J4-1) and +24V (J4-2), or connecting NO (J4-4) and +24V (J4-3). The port diagram is shown in Figure 2-23, and the port description is shown in Table 2-9.

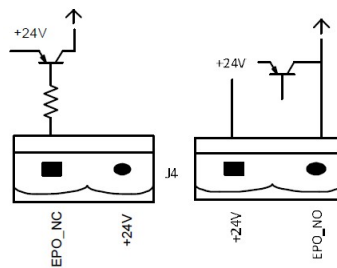

Figure 2-23 Diagram of input port for remote EPO

Table 2-9 Description of input port for remote EPO

Port	Name	Function
J4-1	REMOTE_EPO_NC	Trigger EPO when disconnect with J4-2
J4-2	+24V_DRY	+24V
J4-3	+24V_DRY	+24V
J4-4	REMOTE_EPO_NO	Trigger EPO when connect with J4-3

 **Note**

J4-1 and J4-2 must be connected in normal operations.

Generator Input Dry Contact

The default function of J5 is the interface for generator input, when connecting J5-2 with +24V (J5-1), the UPS judges the generator has been connected in the system. The port diagram is shown in Figure 2-24, the port description is shown in Table 2-10.

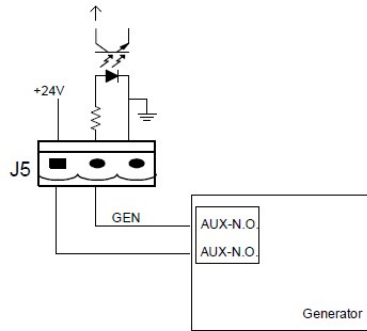

Figure 2-24 Diagram of input port for generator input

Table 2-10 Description of input port for generator input

Port	Name	Function
J5-1	+24V_DRY	+24V
J5-2	GEN_CONNECTED	Connection status of generator
J5-3	GND_DRY	Power ground for +24V

BCB Input Port

The default functions of J6 and J7 are the ports for BCB tripping and BCB status, connect J6-1 and J7-1 to BCB tripper, the port J6-1 can provide a driver signal (+24VDC, 20mA) to trip the battery breaker when EPO is triggered or EOD (end of discharge) happen. Connect J6-2 and J7-1 to BCB auxiliary contact points after shorting circuit J7-1 and J7-2, the UPS would detect the BCB status, when BCB is closed, it indicates batteries are connected, when open, it alarms batteries not connected. The port diagram is shown in Figure 2-25, and the description is shown in Table 2-11.

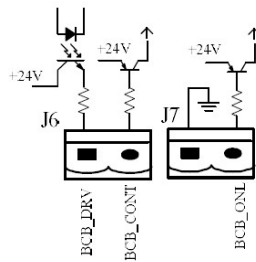

Figure 2-25 BCB Port

Table 2-11 Description of BCB port

Port	Name	Function
J6-1	BCB_DRIV	BCB contact drive, provides +24V voltage, 20mA drive signal
J6-2	BCB_Status	BCB contact status, connect with the normally open signal of BCB
J7-1	GND_DRY	Power ground for +24V
J7-2	BCB_Online	BCB on-line input (normally open), BCB is on-line when the signal is connecting with J7-1

 **Note**

In default setting, when a circuit breaker with auxiliary contacts is used, connect J6-2 and J7-1 to auxiliary contacts terminals to get the status of the BCB, this function must be enabled by shorting J7-1 and J7-2.

Battery Warning Output Dry Contact Interface

The default function of J8 is the output dry contact interface for battery voltage low alarm, when the battery voltage is lower than the setting value, an auxiliary dry contact signal will be activated via the relay, before UPS alarms “Battery voltage low”, J8-1 and J8-3 are connected by the relay, J8-2 and J8-3 are disconnected, when UPS alarms “battery voltage low”, J8-1 and J8-3 are disconnected by the relay, J8-2 and J8-3 are connected.

The port diagram is shown in Figure 2-26, and the description is shown in Table 2-12.

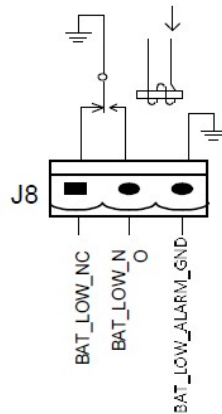

Figure 2-26 Battery warning output dry contact interface diagram

Table 2-12 Battery warning output dry contact interface description

Port	Name	Function
J8-1	BAT_LOW_ALARM_NC	Battery warning relay (normally closed) will be open during warning
J8-2	BAT_LOW_ALARM_NO	Battery warning relay (normally open) will be closed during warning
J8-3	BAT_LOW_ALARM_GND	Common terminal

General Alarm Output Dry Contact Interface

The default function of J9 is the general alarm output dry contact dry interface. When one and more warnings are triggered, an auxiliary dry contact signal will be active via the isolation of a relay. The port diagram is shown in Figure 2-27, and the description is shown in Table 2-13.

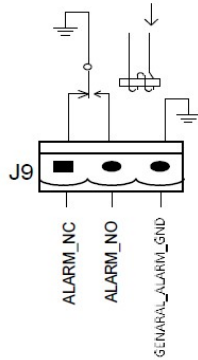

Figure 2-27 General alarm dry contact interface diagram

Table 2-13 General alarm dry contact interface description

Port	Name	Function
J9-1	GENERAL_ALARM_NC	Integrated warning relay (normally closed) will be open during warning
J9-2	GENERAL_ALARM_NO	Integrated warning relay (normally open) will be closed during warning
J9-3	GENERAL_ALARM_GND	Common terminal

Utility Fail Warning Output Dry Contact Interface

The default function of J10 is the output dry contact interface for utility failure warning, when the utility fails, the system will send a utility failure warning information, and provide an auxiliary dry contact signal via the isolation of a relay. The interface diagram is shown in Figure 2-28, and the description is shown in Table 2-13.

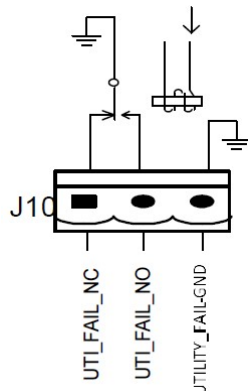

Figure 2-28 Utility failure warning dry contact interface diagram

Table 2-13 Utility failure warning dry contact interface description

Port	Name	Function
J10-1	UTILITY_FAIL_NC	Mains failure warning relay(normally closed) will be open during warning
J10-2	UTILITY_FAIL_NO	Mains failure warning relay (normally open) will be closed during warning
J10-3	UTILITY_FAIL_GND	Common terminal

2.7.2 Communication Interface

RS232, RS485 and USB ports can provide series data which can be used for commissioning and maintenance by authorized engineers or can be used for networking or integrated monitoring system in the service room. SNMP is used on site for communication (Optional).

3 Control and LCD display Panel

The structure of control and display panel for cabinet is shown in Figure 3-1.

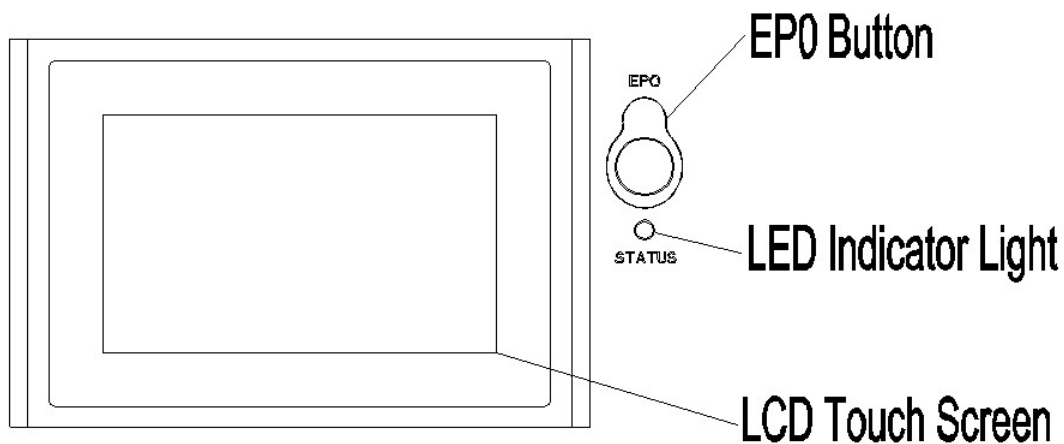

Figure 3-1 Control and display panel

The panel is divided into three functional areas: LED indicator, EPO (Emergency Power Off) button and LCD screen.

3.1 LCD Indicator

If no alarm or fault, the status indicator light always be green, when any alarm or fault occurs, the light should turn red.

There are two different types of audible alarm during UPS operation, as shown in Table 3-1.

Table 3-1 Description of audible alarm

Alarm	Description
Two short alarm with a long one	when system has general alarm (for example: AC fault),
Continuous alarm	When system has serious faults (for example: fuse or hardware fault)

3.2 EPO Button

Press EPO button and hold for 2.5 seconds, UPS should cut down the output (shut down the rectifier, the inverter, the charger, the static bypass), and the load will lose the power.

Note: EPO function is used in emergency cases, for example, fire alarm, don't use it carelessly, otherwise, the load will lose the power.

3.3 LCD Touch Screen

After the monitoring system starts self-test, the system enters the home page, following the

welcome window. The home page is shown in Figure 3-2.

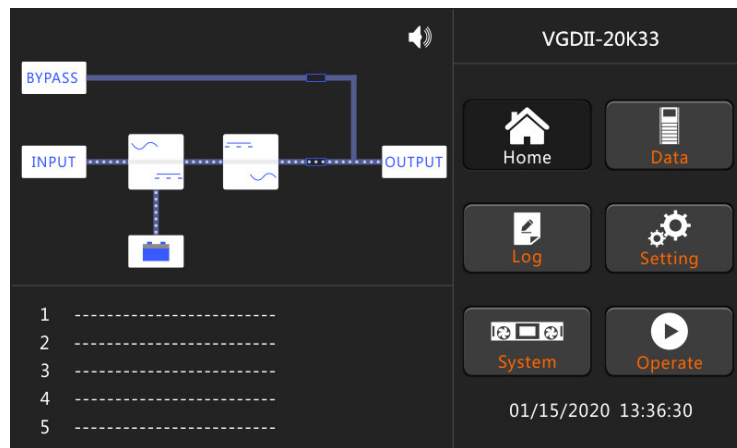

Figure 3-2 Home page

Home page consists of Status bar, warning information and main menu.

● **Status bar**

Status bar contains the model of the product, capacity, operational mode and the time of the system.

● **Warning Information**

Display the warning information of the cabinet.

● **Main Menu**

Main menu includes Cabinet, Data, Setting, Log, Operate and System. Users can operate and control the UPS, and browse all measured parameters through main menu.

3.4 Main Menu

Main menu includes Cabinet, Data, Setting, Log, Operate and System and it is described in details below.

3.4.1 Data

Touch “Data” icon and the system enters the page of the Data, as it is shown in Figure 3-3.

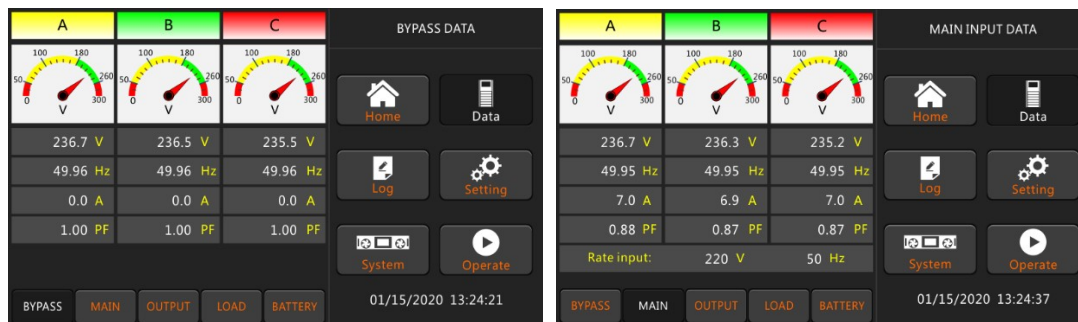



Figure 3-3 Submenu Interface of Data Page

3.4.2 Log

Touch the “Log” icon, and the system enters the interface of the Log, as it is shown in Figure 3-4. The log is listed in reverse chronological order (i.e. the first on the screen with #1 is the most new), which displays the events, warnings and faults information and the data and time they occur and disappear.

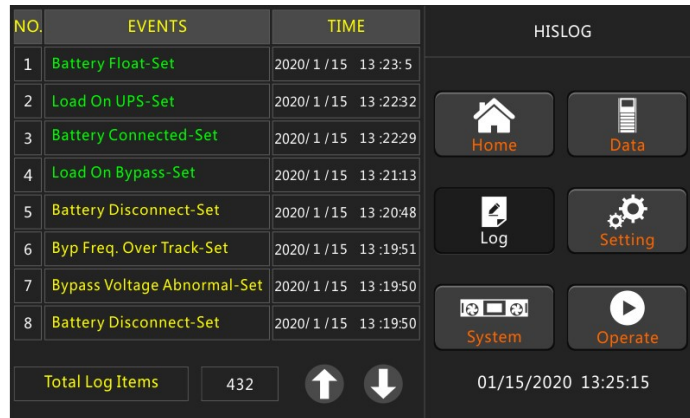

Figure 3-4 Log Page

The following Table 3-2 shows events of UPS History Log.

String Sequence	LCD Display	Explanation
1	Load On UPS-Set	Load On UPS
2	Load On Bypass-Set	Load On Bypass
3	No Load-Set	No Load (Output Power Lost)
4	Battery Boost-Set	Charger is Boosting Battery Voltage
5	Battery Float-Set	Charger is Floating Battery Voltage
6	Battery Discharge-Set	Battery is Discharging

7	Battery Connected-Set	Battery cables Connected
8	Battery Not Connected-Set	Battery cables Disconnected.
9	Maintenance CB Closed-Set	Maintenance CB is Closed
10	Maintenance CB Open-Set	Maintenance CB is Open
11	EPO-Set	Emergency Power Off
12	Module On Less-Set	Valid Inverter capacity is less than the load capacity
13	Module On Less-Clear	Incident above disappears
14	Generator Input-Set	Generator as the Ac Input Source
15	Generator Input-Clear	Incident above disappears
16	Utility Abnormal-Set	Utility (Grid) Abnormal
17	Utility Abnormal-Clear	Incident above disappears
18	Bypass Sequence Error-Set	Bypass voltage Sequence is reverse
19	Bypass Sequence Error-Clear	Incident above disappears
20	Bypass Volt Abnormal-Set	Bypass Voltage Abnormal
21	Bypass Volt Abnormal-Clear	Incident above disappears
22	Bypass Module Fail-Set	Bypass Module Fail
23	Bypass Module Fail-Clear	Incident above disappears
24	Bypass Overload-Set	Bypass Over load
25	Bypass Overload-Clear	Incident above disappears
26	Bypass Overload Tout-Set	Bypass Over Load Timeout
27	Byp Overload Tout-Clear	Incident above disappears
28	Byp Freq Over Track-Set	Bypass Frequency Over Track Range
29	Byp Freq Over Track-Clear	Incident above disappears
30	Exceed Tx Times Lmt-Set	Transfer times (from inverter to bypass) in 1 hour exceed the limit.
31	Exceed Tx Times Lmt-Clear	Incident above disappears
32	Output Short Circuit-Set	Output shorted Circuit
33	Output Short Circuit-Clear	Incident above disappears
34	Battery EOD-Set	Battery End Of Discharge
35	Battery EOD-Clear	Incident above disappears
36	Battery Test-Set	Battery Test Starts
37	Battery Test OK-Set	Battery Test OK
38	Battery Test Fail-Set	Battery Test fails
39	Battery Maintenance-Set	Battery Maintenance Starts
40	Batt Maintenance OK-Set	Battery maintenance succeeds
41	Batt Maintenance Fail-Set	Battery maintenance fails
44	Rectifier Fail-Set	Rectifier Fails

45	Rectifier Fail-Clear	Incident above disappears
46	Inverter Fail-Set	Inverter Fail
47	Inverter Fail-Clear	Incident above disappears
48	Rectifier Over Temp.-Set	Rectifier Over Temperature
49	Rectifier Over Temp.-Clear	Incident above disappears
50	Fan Fail-Set	Fan Fail
51	Fan Fail-Clear	Incident above disappears
52	Output Overload-Set	Output Over Load
53	Output Overload-Clear	Incident above disappears
54	Inverter Overload Tout-Set	Inverter Over Load Timeout
55	INV Overload Tout-Clear	Incident above disappears
56	Inverter Over Temp.-Set	Inverter Over Temperature
57	Inverter Over Temp.-Clear	Incident above disappears
58	On UPS Inhibited-Set	Inhibit system transfer from bypass to UPS (inverter)
59	On UPS Inhibited-Clear	Incident above disappears
60	Manual Transfer Byp-Set	Transfer to bypass manually
61	Manual Transfer Byp-Set	Cancel to bypass manually
62	Esc Manual Bypass-Set	Escape transfer to bypass manually command
63	Battery Volt Low-Set	Battery Voltage Low
64	Battery Volt Low-Clear	Incident above disappears
65	Battery Reverse-Set	Battery pole (positive and negative are reverse)
66	Battery Reverse-Clear	Incident above disappears
67	Inverter Protect-Set	Inverter Protect (Inverter Voltage Abnormal or Power Back feed to DC Bus)
68	Inverter Protect-Clear	Incident above disappears
69	Input Neutral Lost-Set	Input Grid Neutral Lost
70	Bypass Fan Fail-Set	Bypass Module Fan Fail
71	Bypass Fan Fail-Clear	Incident above disappears
72	Manual Shutdown-Set	Manually Shutdown
73	Manual Boost Charge-Set	Manually Battery Boost Charge
74	Manual Float Charge-Set	Manually Battery Float Charge
75	UPS Locked-Set	Inhibit to shut down the UPS
76	Parallel Cable Error-Set	Parallel cable in error
77	Parallel Cable Error-Clear	Incident above disappears
78	Lost N+X Redundant	Lost N+X Redundant
79	N+X Redundant Lost-Clear	Incident above disappears
80	EOD Sys Inhibited	System is inhibited to supply after the battery is EOD (end of discharging)

81	Power Share Fail-Set	Power share is not in balance
82	Power Share Fail-Clear	Incident above disappears
83	Input Volt Detect Fail-Set	Input Voltage is abnormal
84	Input Volt Detect Fail-Clear	Incident above disappears
85	Battery Volt Detect Fail-Set	Battery Voltage is abnormal
86	Batt Volt Detect Fail-Clear	Incident above disappears
87	Output Volt Fail-Set	Output Voltage is abnormal
88	Output Volt Fail-Clear	Incident above disappears
89	Outlet Temp. Error-Set	Outlet Temperature is abnormal
90	Outlet Temp. Error-Clear	Incident above disappears
91	Input Curr Unbalance-Set	Input current is not balance
92	Input Curr Unbalance-Clear	Incident above disappears
93	DC Bus Over Volt-Set	DC bus over Voltage
94	DC Bus Over Volt-Clear	Incident above disappears
95	REC Soft Start Fail-Set	Rectifier soft start fails
96	REC Soft Start Fail-Clear	Incident above disappears
97	Relay Connect Fail-Set	Relay in open circuit
98	Relay Connect Fail-Clear	Incident above disappears
99	Relay Short Circuit-Set	Relay shorted
100	Relay Short Circuit-Clear	Incident above disappears
101	No Inlet Temp. Sensor-Set	The inlet temperature sensor is not connected or abnormal
102	No Inlet Temp Sensor-Clear	Incident above disappears
103	No Outlet Temp. Sensor-Set	The Outlet temperature sensor is not connected or abnormal
104	No Outlet TmpSensor-Clear	Incident above disappears
105	Inlet Over Temp.-Set	Inlet over temperature
106	Inlet Over Temp.-Clear	Incident above disappears

3.4.3 Setting

Touch the “Setting” icon, and the system enters the page of Setting, as it is shown in Figure 3-5.

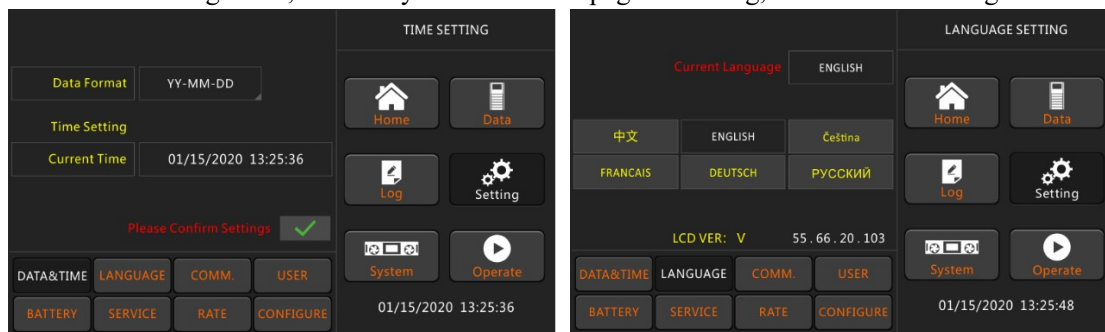



Figure 3-5 Submenu Interface of Setting Page

The submenus are listed on the bottom side of the Setting page. Users can enter each of the setting interfaces by touching the relevant icon. The submenus are described in details below in Table 3-3.

Table 3-3 Description of each submenu of Setting

Submenu Name	Contents	Meaning
Date & Time	Date format setting	Three formats: (a) year/month/day,(b) month/date/year, (c) date/month/year
	Time setting	Setting time
Language	Current language	Language in use
	Language selection	Simplified Chinese and English selectable (The setting taking action immediately after touching the language icon)
COMM.	Device Address	Setting the communication address
	RS232 Protocol Selection	SNT Protocol, Modbus Protocol, YD/T Protocol and Dwin (For factory use)
	Baud rate	Setting the baud rate of SNT, Modbus and YD/T
	Modbus Mode	Setting mode for Modbus: ASCII and RTU selectable
USER	Output voltage Adjustment	Setting the Output Voltage

Submenu Name	Contents	Meaning
	Bypass Voltage Up Limited	Up limited working Voltage for Bypass, settable:+10%, +15%, +20%, +25%
	Bypass Voltage Down Limited	Down limited working Voltage for Bypass, settable:-10%, -15%, -20%, -30%, -40%
	Bypass Frequency Limited	Permitted working Frequency for Bypass Settable: +-1Hz, +-3Hz, +-5Hz
BATTERY	Battery Number	Setting the number of the battery (12V)
	Battery Capacity	Setting of the AH of the battery
	Float Charge Voltage/Cell	Setting the floating Voltage for battery cell (2V)
	Boost Charge Voltage/Cell	Setting the boost Voltage for battery cell (2V)
	Charge Current Percent Limit	Charge current (percentage of the rated current)
SERVICE	System Mode	Setting the system mode: Single , parallel, Single ECO, parallel ECO, LBS, parallel LBS
	Parallel number	Parallel system UPS numbers
	Parallel ID	UPS ID in parallel system
	Slew rate	Bypass frequency slew rate
	Synchronization window	Bypass frequency slew window
	System auto start mode after EOD	UPS start mode after battery end of discharging
RATE	Configure the rated Parameter	For the factory use
CONFIGURE	Display mode	Support Tower and Rack LCD display
	Back light time	LCD back light time
	Contrast	LCD contrast

3.4.4 System

System Information Window displays software version, Bus voltage, charger voltage, and so on, these menus “Status&Alarm”, “REC Code”, and “INV Code” are helpful to maintain the UPS, as is shown in the following Figure 3-6.

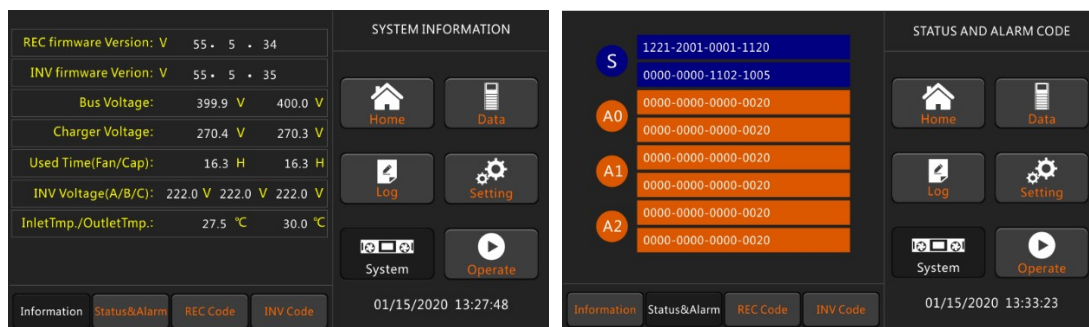

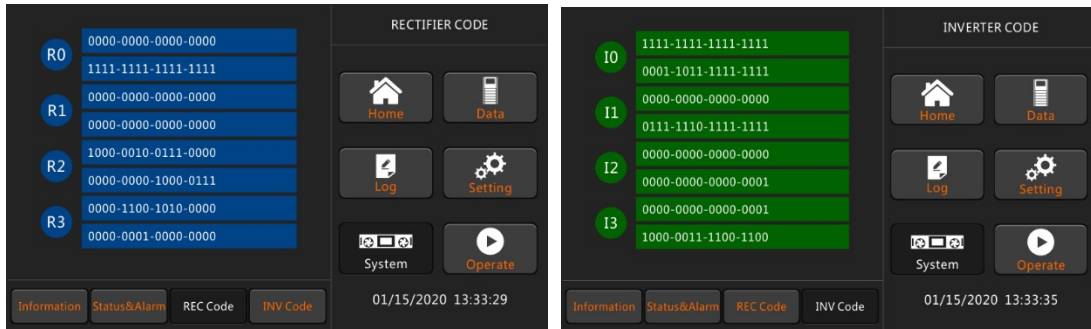

Figure 3-6 Submenu Interface of System Page

3.4.5 Operate

Touch the “Operate” icon, and the system enters the page of “Operate”, as it is shown in Figure 3-7.

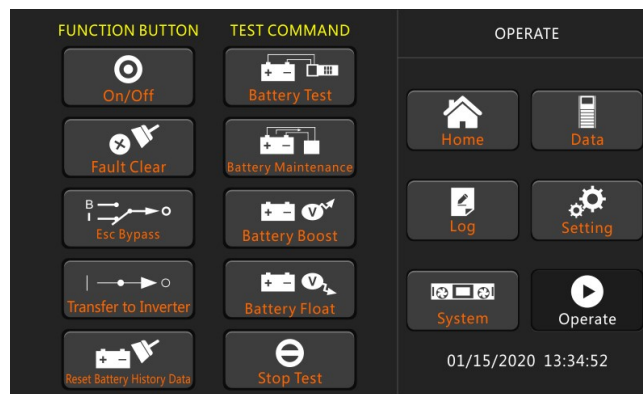

Figure 3-7 Operate Page

The “Operate” menu includes FUNCTION BUTTON and TEST COMMAND. The contents are described in details below.

FUNTION BUTTON

- **On/Off**

Manual turn ON/OFF UPS

- **Fault Clear**

Clear the faults by touching the icon.

- **Transfer to Bypass**

Transfer to bypass mode by touching the icon

- **Transfer to Inverter**

Transfer the bypass mode to Inverter Mode by touching the icon.

- **Reset Battery History Data**

Reset the battery history data by touching the icon, the history data includes the times of discharge, days for running and hours of discharging.

TEST COMMAND

- **Battery Test**

By touching the icon, the system transfer to the Battery mode to test the condition of the battery. Ensure the bypass is working normally and the capacity of the battery is no less than 25%.

- **Battery Maintenance**

By touching the icon, the system transfers to the Battery mode. This function is used for maintaining the battery, which requires the normality of the bypass and minimum capacity of 25% for the battery.

- **Battery Boost**

By touching the icon, the system starts boost charging.

- **Battery Float**

By touching the icon, the system starts float charging.

- **Stop Test**

By touching the icon, the system stops battery test or battery maintenance.

4 Operations

4.1 UPS start-up

4.1.1 Startup in normal mode

The UPS must be started up by commissioning engineer after the completeness of installation. The steps below must be followed:

- 1) Ensure all the circuit breakers are open. One by one to turn on the output breaker, input breaker, bypass input breaker, and then the system starts initializing.
- 2) The LCD in front of the cabinet is lit up. The system enters the home page, as shown in Figure 3-2.
- 3) Notice the energy flowing diagram and alarms on the home page, as is shown in Figure 4-1.

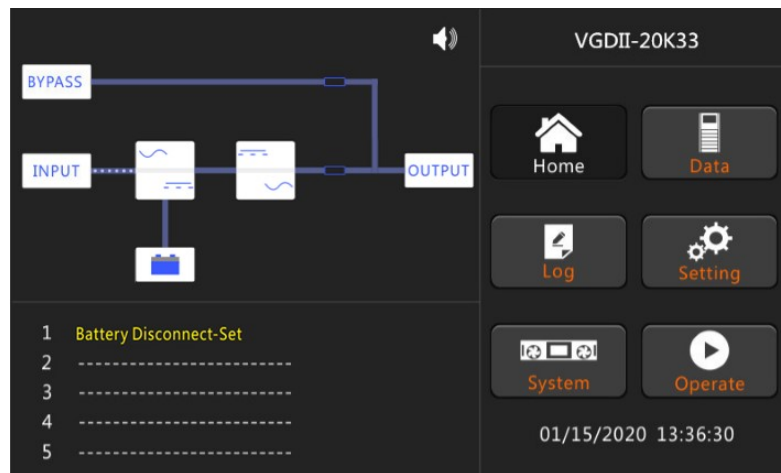

Figure 4-1 Rectifier starting

- 4) After about 30S, the rectifier start is completed, the bypass static switch is on, and the bypass indicator flashes. As shown in Figure 4-2.

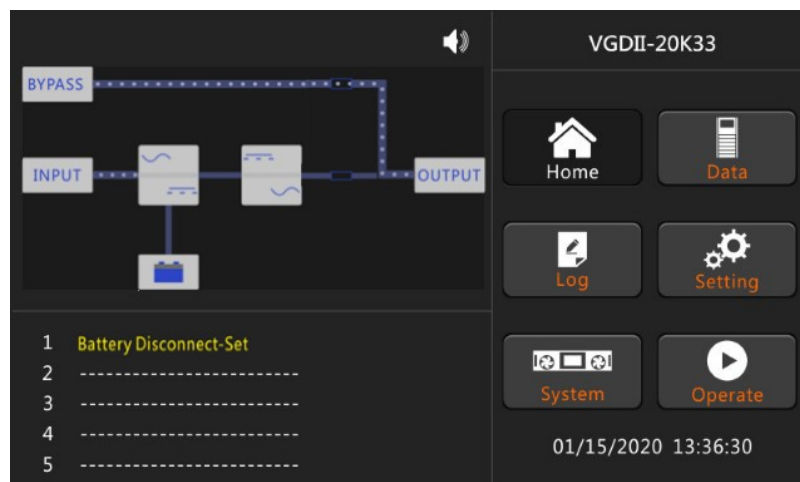

Figure 4-2 Bypass starting

- 5) After the bypass static switch is on, the inverter starts and the inverter indicator bar flashes

as shown in Figure 4-3.

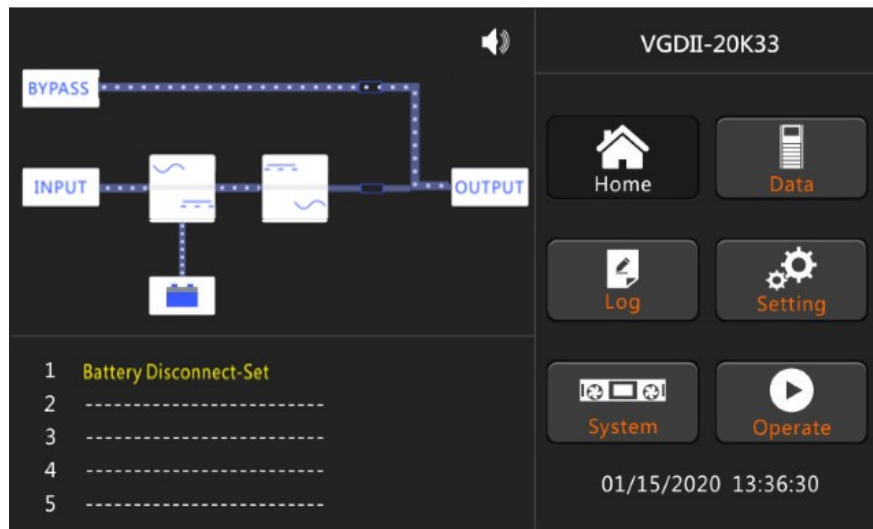

Figure 4-3 Inverter starting

6) After about 30S, when the inverter is running normally, the UPS switches from the bypass to the inverter, the bypass indicator bar is off, and the load indicator bar flashes. As shown in Figure 4-4.

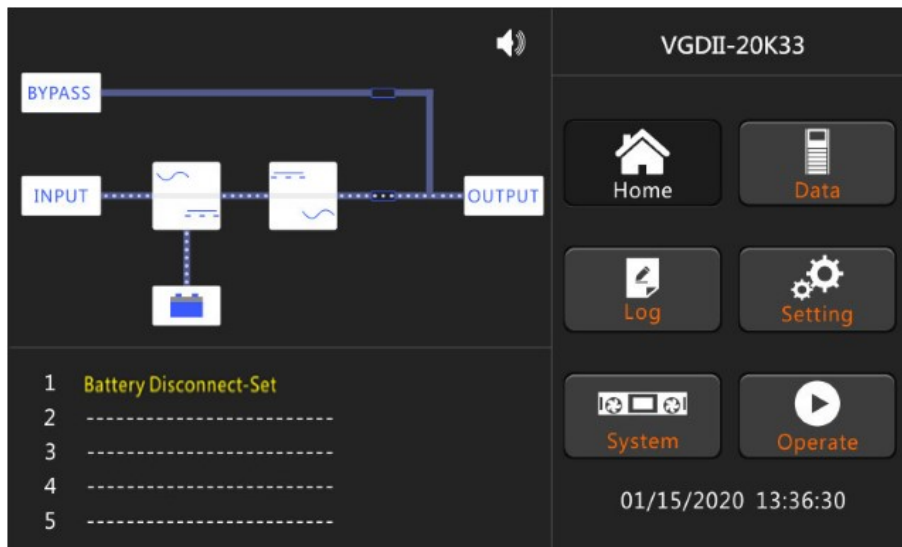

Figure 4-4 Normal mode

7) The startup has finished, users can close the external or internal battery breaker, the main output breaker, and then close the branch breakers one by one. Figure 4-5 shows the completeness of starting.

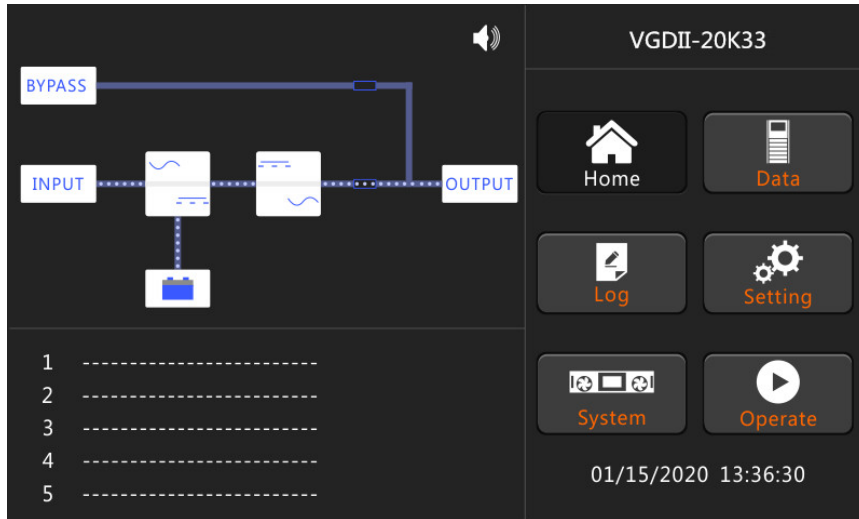

Figure 4-5 Starting completed

Note

- When the system starts, the stored setting will be loaded.
- Users can browse all events during the process of the starting up by checking the menu Log.

4.1.2 Start from battery

The start from battery refers to the battery cold start. The steps of the start-up are as follow:

- 1) Confirm the batteries are correctly connected, and then close the external battery circuit breakers.
- 2) Press and hold the red button of battery cold start until the energy flowing is lighted and flashing, it indicates the system is been powering by the batteries. The position of the battery cold start button is shown in Figure 4-6, the energy flowing diagram is shown in Figure 4-7.

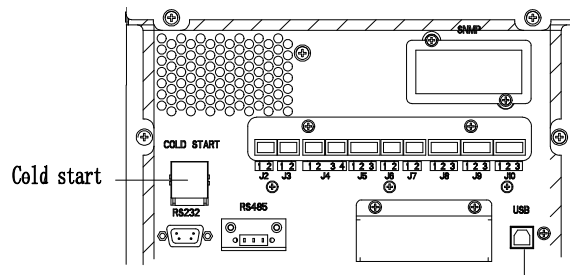

Figure 4-6 Position of the battery cold start button

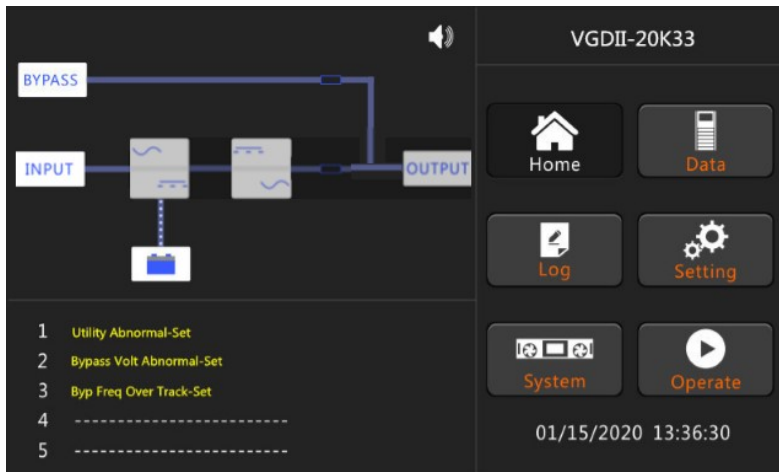

Figure 4-7 Energy flowing diagram of discharge

3) After about 60 seconds, the rectifier completes the start, and the inverter begins to start, and after 30 seconds, the inverter complete the start, and supply the power to the output. The energy flowing diagram is shown in Figure 4-8.

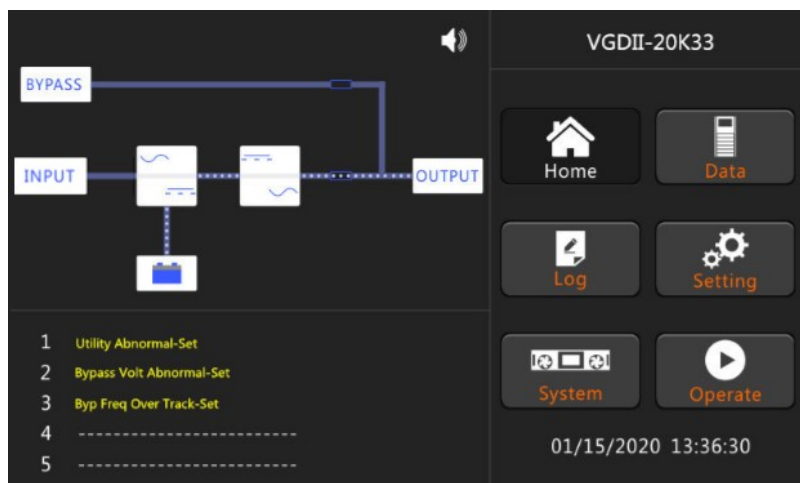

Figure 4-8 Energy flowing diagram of the start completed from batteries

4) Close the external output power supply isolators to supply the loads, and the system is working in battery mode.

4.2 UPS Shut down

If need to shut down UPS completely, please first ensure the load is shut down correctly, and then turn off the external battery breaker, the main input breaker (internal or external), the bypass input breaker (internal or external, if have) one by one, the display screen will be off completely.

Note: If UPS in maintenance bypass mode, please also turn off the maintenance bypass breaker.

4.3 Procedure for Switching between Operation Modes

4.3.1 Switching the UPS from normal mode into battery mode

The UPS transfers to battery mode immediately after the utility (mains voltage) fails or drops down below the predefined limit.

4.3.2 Switching the UPS from normal mode into bypass mode

Touching the icon  and then input the password “1203” to transfer the system to Bypass Mode.



Warning

Ensure the bypass is working normally before transferring to bypass mode. Or it may cause failure.

4.3.3 Switching the UPS into normal mode from bypass mode

Touch the icon , UPS will return to Normal Mode from bypass mode.

Note

Normally, the system will transfer to the Normal mode automatically. This function is used when the frequency of the bypass is over track and when the system needs to transfer to Normal mode by manual.

4.3.4 Switching the UPS into maintenance bypass mode from normal mode

These following procedures can transfer the load from the UPS inverter output to the maintenance bypass supply, which is used for maintaining the UPS.

1. Transfer the UPS into Bypass mode as per the chapter 4.3.2.
2. Remove the cover of maintenance bypass breaker.
3. Turn on the maintenance bypass breaker. And the load is powered through maintenance bypass and static bypass.
4. One by one to turn off the battery breaker, input breaker, bypass input breaker and output breaker.
5. The load is powered through maintenance bypass.

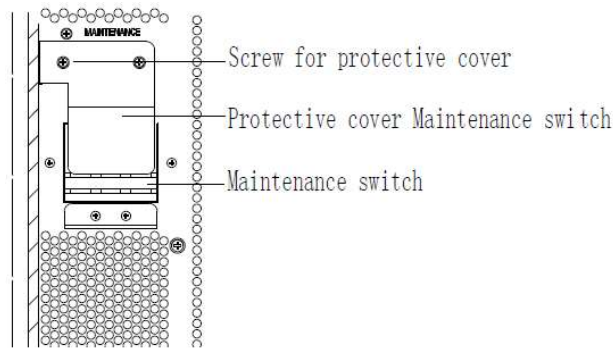

Figure 4-9 Cover of maintenance bypass breaker

 **Warning**

Once the cover on the maintenance bypass breaker is removed, the system will transfer to bypass mode automatically.

 **Warning**

Before making this operation, confirm the messages on LCD display to ensure that bypass supply is regular and the inverter is synchronous with it, so as not to risk a short interruption in powering the load.

 **Danger**

Even with the LCD turned off, the terminals of input and output may be still energized.

Wait for 10 minutes to let the DC bus capacitor fully discharge before removing the cover.

4.3.5 Switching the UPS into normal mode from maintenance bypass mode

These following procedures can transfer the load from the Maintenance Bypass mode to inverter output.

1. After finish of maintenance. One by one to turn on the output breaker, bypass input breaker, input breaker and battery breaker.
2. After 30S, the bypass indicator LED goes green and the load is powered through maintenance bypass breaker and static bypass.
3. Turn off the maintenance bypass breaker and fix the protection cover, and then the load is powered through static bypass. The rectifier starts followed by the inverter.
4. Operate “Fault Clear” as per chapter 3.4.5.
5. After 60 seconds, the system transfers to normal mode.

 **Warning**

The system will stay on bypass mode until the cover of maintenance bypass breaker is fix.

4.4 Battery Maintenance

If batteries not discharged for a long time, it is necessary to test the condition of batteries.

Touch the icon  Battery Maintenance, and input the password “1203”, the system transfers into Battery Mode for discharge. If no human intervention, the system will continue to discharge until the alarm of “Battery low voltage” is given. Users can stop the discharge by touching the icon



Touch the icon  Battery Test, the system will discharge for about 30 seconds, and then re-transfer to normal mode.

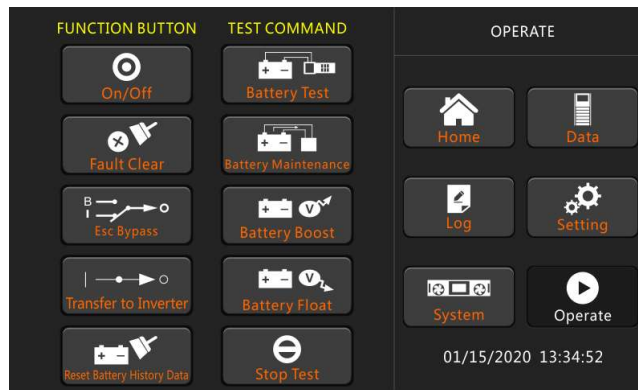

Figure 4-10 Battery maintenance

Warning

The load for the auto maintenance discharge should be 20%-100%, if not, the system will not start the process automatically.

4.5 EPO

The EPO button is located on the front panel (with the cover to avoid disoperation), which is designed to switch off the UPS in emergency conditions (e.g., fire, flood, etc.). To achieve this, just press the EPO button and hold for 2.5 seconds, the system will turn off the rectifier, inverter and stop powering the load immediately (including the inverter and bypass output), and the battery stops charging or discharging.

If the input utility is present, the UPS control circuit will remain active; however, the output will be turned off. To completely isolate the UPS, users need to open the external mains input supply to the UPS.

Warning

When the EPO is triggered, the load is not powered by the UPS. Be careful to use the EPO function.

4.6 Installation of parallel operation system

Normally 4 cabinets can be paralleled; and the parallel function is optional, if users need the function, please confirm the configuration with the supplier in advance. For the details of the parallel system, please refer to the annex “Instructions of the parallel system for UPS”.

5 Maintenance

This chapter introduces UPS maintenance, including the maintenance instructions of power module and monitoring bypass module and the replacement method of dust filter.

5.1 Precautions

Only maintaining engineers can maintain the power module and monitoring bypass module.

- 1) The power module should be disassembled from top to bottom, so as to prevent any inclination from high gravity center of the cabinet.
- 2) To ensure the safety before maintaining power module and bypass module, use a multi-meter to measure the voltage between operating parts and the earth to ensure the voltage is lower than hazardous voltage, i.e. DC voltage is lower than 60Vdc, and AC maximum voltage is lower than 42.4 Vac.
- 3) Bypass module is not recommended to hot swap; only when UPS is in Manual Bypass Mode or UPS is completely powered off, the bypass module can be disassembled.
- 4) Wait 10 minutes before opening the cover of the power module or the bypass after pulling out from the cabinet.

5.2 Instruction for maintaining UPS

For the maintenance of the UPS, please refer to Chapter 4.3.4 to transfer to maintenance bypass mode. After maintenance, re-transfer to normal mode according to Chapter 4.3.5.

5.3. Instruction for Maintaining Battery String

For the Lead-Acid maintenance free battery, when maintaining the battery according to requirements, battery life can be prolonged. The battery life is mainly determined by the following factors:

- 1) Installation. The battery should be placed in dry and cool place with good ventilation. Avoid direct sunlight and keep away from heat source. When installing, ensure the correct connection to the batteries with same specification.
- 2) Temperature. The most suitable storage temperature is 20 °C to 25°C.
- 3) Charging/discharging current. The best charging current for the lead-acid battery is 0.1C. The maximum charging current for the battery can be 0.2C. The discharging current should be 0.05C-3C.
- 4) Charging voltage. In most of the time, the battery is in standby state. When the utility is normal, the system will charge the battery in boost mode (constant voltage with maximum limited) to full and then transfers to the state of float charge.
- 5) Discharge depth. Avoiding deep discharge, which will greatly reduce the life time of the battery.

When the UPS runs in battery mode with light load or no load for a long time, it will cause the battery to deep discharge.

6) Check periodically. Observe if any abnormality of the battery, measure if the voltage of each battery is in balance. Discharge the battery periodically.



Warning

Daily inspection is very important!

Check and confirm the battery connection is tightened regularly, and make sure there is no abnormal heat generated from the battery.



Warning

If one battery has leakage or is damaged, it must be replaced, stored in a container resistant to sulfuric acid and disposed of in accordance with local regulations.

The waste lead-acid battery is a kind of hazardous waste and is one of the major contaminants controlled by government.

Therefore, its storage, transportation, use and disposal must comply with the national or local regulations and laws about the disposal of hazardous waste and waste batteries or other standards. According to the national laws, the waste lead-acid battery should be recycled and reused, and it is prohibited to dispose of the batteries in other ways except recycling. Throwing away the waste lead-acid batteries at will or other improper disposal methods will cause severe environment pollution, and the person who does this will bear the corresponding legal responsibilities.

6 Product Specifications

This chapter provides the specifications of the product, including environment characteristics mechanical characteristics and electrical characteristics.

6.1 Applicable Standards

The UPS has been designed to conform to the following European and international standards:

Table 6-1 Compliance with European and International Standards

Item	Normative reference
General safety requirements for UPS used in operator access areas	IEC62040-1-1
Electromagnetic compatibility (EMC) requirements for UPS	IEC62040-2
Method of specifying the performance and test requirements of UPS	IEC62040-3

Note

The above mentioned product standards incorporate relevant compliance clauses with generic IEC and EN standards for safety (IEC/EN/AS60950), electromagnetic emission and immunity (IEC/EN61000 series) and construction (IEC/EN60146 series and 60950).

6.2 Environmental Characteristics

Table 6-2 Environmental Characteristics

Item	Unit	Parameter
Acoustic noise level at 1 meter	dB	58dB @ 100% load, 55dB @ 45% load
Altitude of Operation	m	≤1000, load de-rated 1% per 100m from 1000m to 2000m
Relative Humidity	%	0-95, non-condensing
Operating Temperature	°C	0-40(for UPS only), Battery life is halved for every 10°C increase above 20°C
UPS Storage Temperature	°C	-40-70

6.3 Mechanical Characteristics

Table 6-3 Mechanical Characteristics for Cabinet

Model	Unit	VGDII-10-15 K33XL	VGDII-10-15 K33	VGDII-20-30K 33XL	VGDII-20-30K 33	VGDII-40K33 XL	VGDII-40K33
Dimension W×D×H	mm	250*770*530	250*880*715	250*800*770	350*765*1335	250*900*770	500*860*1400
Weight	kg	31	51.5	89	52	61	140
Color	N/A	BLACK,RAL 7021					
Protection Level IEC (60529)	N/A	IP20					

6.4 Electrical Characteristics

6.4.1 Electrical Characteristics (Input Rectifier)

Table 6-4 Rectifier AC input Mains

Item	Unit	Parameter
Grid System	\	3 Phases + Neutral + PE
Rated AC Input Voltage	Vac	380/400/415(three-phase and sharing neutral with the bypass input)
Rated Frequency	Vac	50/60Hz
Input Frequency	Hz	40~70
Input Power factor	\	>0.99

6.4.2 Electrical Characteristics (Intermediate DC Link)

Table 6-5 Battery

Items	Unit	Parameters
Battery bus voltage	Vdc	Rated: ±240V
Quantity of lead-acid cells	Nominal	40=[1 battery(12V)] ,240=[1 battery(2V)]
Float charge voltage	V/cell (VRLA)	2.25V/cell(selectable from 2.2V/cell~2.35V/cell) Constant current and constant voltage charge mode
Boost charge voltage	V/cell (VRLA)	2.3V/cell(selectable from : 2.30V/cell~2.45V/cell) Constant current and constant voltage charge mode

Temperature compensation	mV/°C/cl	3.0(selectable:0~5.0)
Final discharging voltage	V/cell (VRLA)	1.65V/cell(selectable from: 1.60V/cell~1.750V/cell) @0.6C discharge current 1.75V/cell (selectable from: 1.65V/cell~1.8V/cell) @0.15C discharge current (EOD voltage changes linearly within the set range according to discharge current)

 **Note**

The default battery number is 40. When the actual battery in use is 32-44, ensure the actual number and the set number is the same, otherwise, batteries may be damaged.

6.4.3 Electrical Characteristics (Inverter Output)

Table 6-6 Inverter Output (To critical load)

Item	Unit	Parameter
Rated capacity	kVA	10~40
Rated AC voltage	Vac	380/400/415 (Line-Line)
Rated Frequency	Hz	50/60
Frequency Regulation	Hz	50/60Hz±0.1%
Power Factor	\	1

6.4.4 Electrical Characteristics (Bypass Mains Input)

Table 6-7 Bypass Mains Input

Item	Unit	Value
Rated AC voltage	Vac	380/400/415 (three-phase four-wire and sharing neutral with the bypass)
Overload	%	125% Long term operation; 125%~130% for 10min; 130%~150% for 1min; 150%~400% for 1s; >400% ,less than 200ms
Current rating of neutral cable	A	1.7×In
Rated frequency	Hz	50/60
Switch time (between bypass and inverter)	ms	Synchronized transfer: 0ms

Bypass voltage range	%	Settable, default -20%~+15% Upper limit: +10%, +15%, +20%, +25% Lower limit: -10%, -15%, -20%, -30%, -40%
Bypass frequency range	%Hz	Settable, ±1Hz, ±3Hz, ±5Hz
Synchronized Range	Hz	Settable ±0.5Hz~±5Hz,default ±3Hz

6.5 Efficiency

Table 6-8 Efficiency

Rated power(kVA)	Unit	VGDII 10-15K	VGDII-20-30 K	VGDII-40 K
Normal mode(dual conversion)	%	95	95	96
Battery discharging efficiency (battery at nominal voltage 480Vdc and full-rated linear load)				
Battery mode	%	94.5	95	96

6.6 Display and Interface

Table 6-10 Display and Interface

Display	LED + LCD
Interface	Standard:RS232, RS485 Option: SNMP, Dry Contact

Annex. A Installation of internal batteries

For VGDII-10-40K33, internal batteries and cables used to connect the batteries are not provided as standard; if required, please contact your local agency.

For VGDII-10-15K33, 40 pieces of 7AH/9AH batteries can be installed.

For VGDII-20-30K33, 40 pieces of 12AH battery can be installed.

For VGDII-40K33, 80 pieces of 12Ah batteries can be installed.

For VGDII-10-15K33, the cabinet can contain 40 batteries, which are divided into 4 layers. Please install the batteries as per the below.

1. Dismantle the covers and crossbeams.

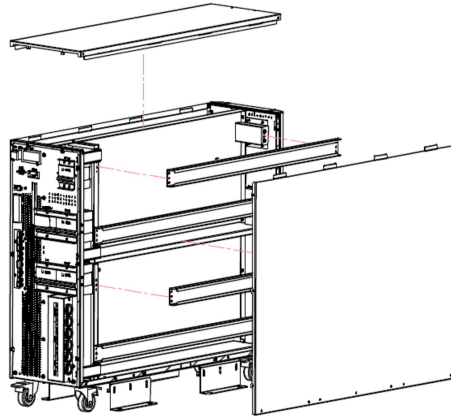

2. Install battery and fix the crossbeams.

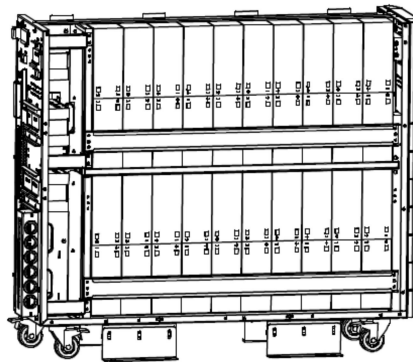

3. Connect the battery cable according to the series number.

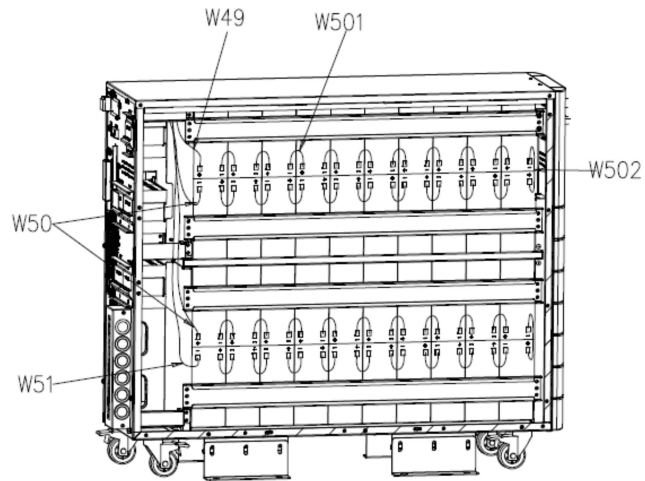

4. Recover the cover.

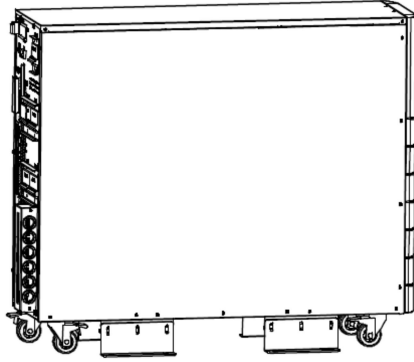

For VGDII-20-30K33, there are 8 groups of battery in series, and per group contains 5 blocks of 12AH batteries. The interconnection among groups is via cable with Anderson Socket. Please refer to the below diagrams.

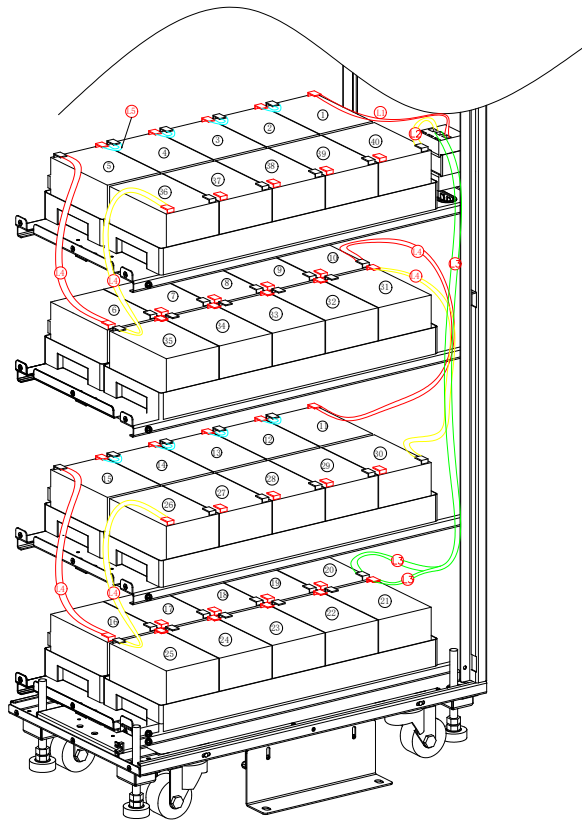

Cable interconnection of the battery string

Layer 1

The positive of the battery 1# is connected to battery breaker CB4-2, via the cable labeled L1, and the negative of battery 40# is connected to CB4-6, via the cable labeled L2.

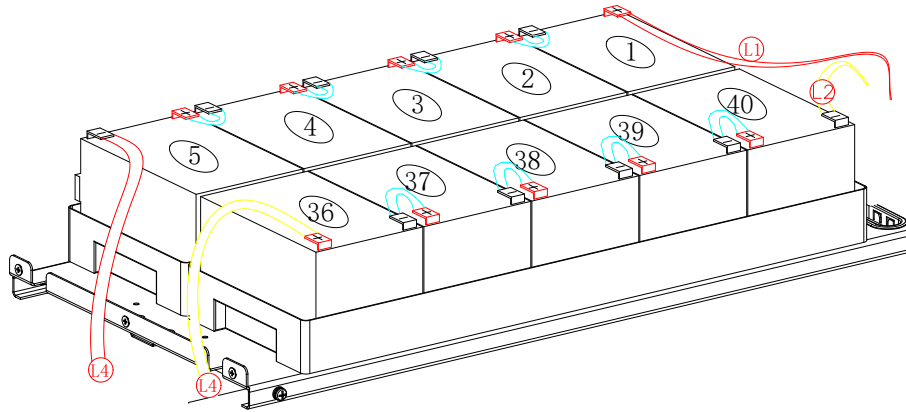

Cable connection of Layer 1

Layer 2

The positive of the battery 6# is connected to the negative of battery 5#, via the cable labeled L4, and the negative of battery 35# is connected to the positive of battery 36#, via the cable labeled L4.

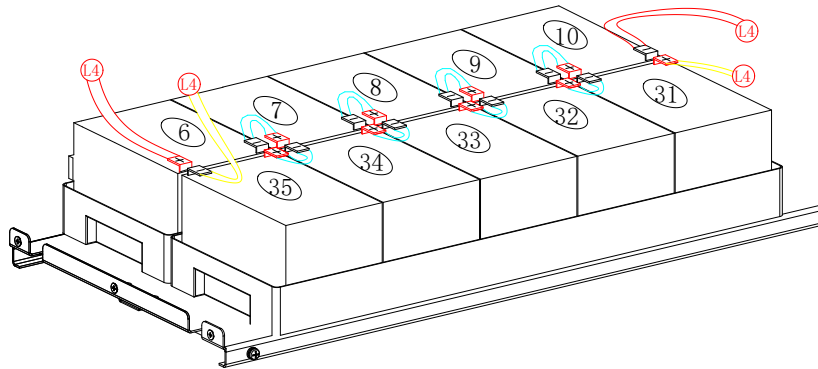

Cable connection of Layer 2

Layer 3

The positive of the battery 11# is connected to the negative of battery 10#, via the cable labeled L4, and the negative of battery 30# is connected to the positive of battery 31#, via the cable labeled L4.

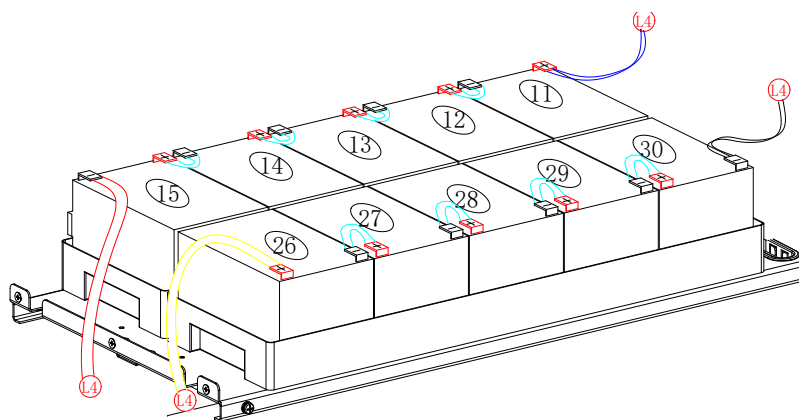

Cable connection of Layer 3

Layer 4

The positive of the battery 16# is connected to the negative of battery 15#, via the cable labeled L4, and the negative of battery 25# is connected to the positive of battery 26#, via the cable labeled L4. The negative of 20# and the positive of 21#, which are defined as the battery neutral, are connected to CB4-4.

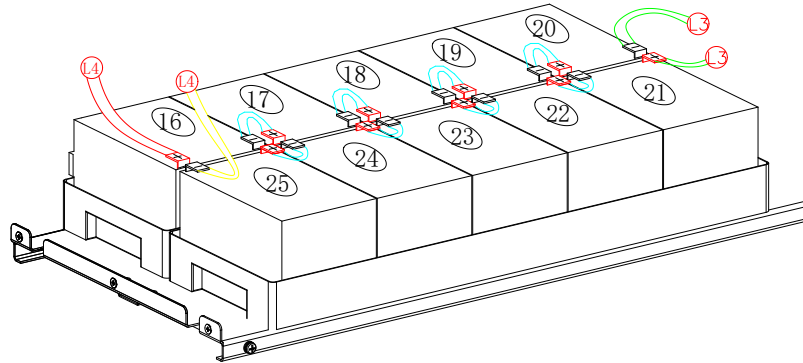

Cable connection of Layer 4

For VGDII-40K33, the battery bank has four layers, each layer has four packages with 5 batteries contained in one package. Below shows the connection of each layer.

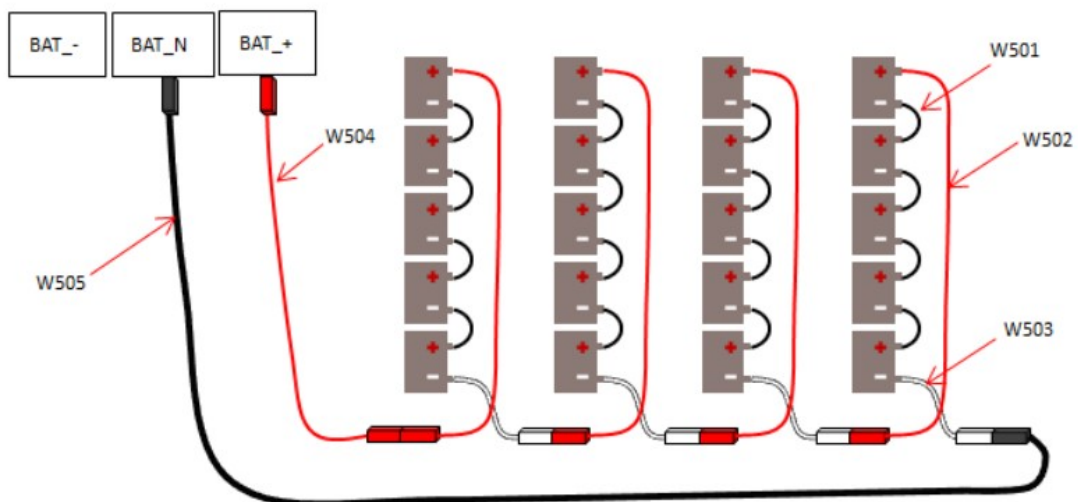

Cable connection of Layer 1

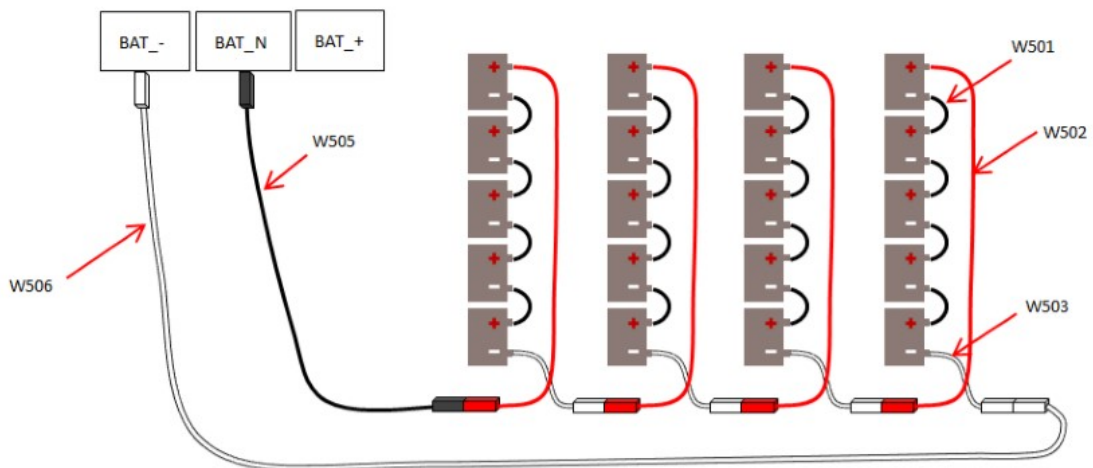

Cable connection of Layer 2

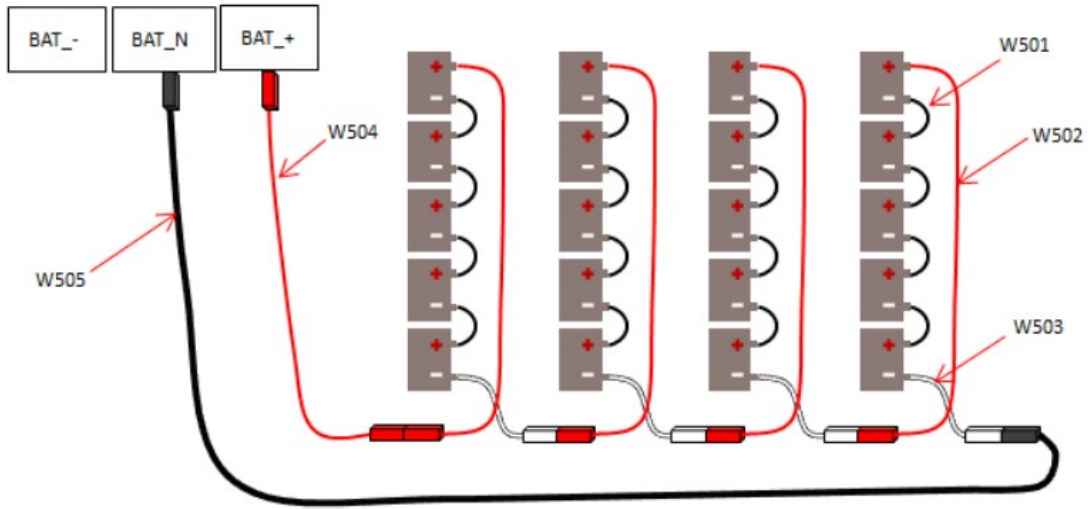

Cable connection of Layer 3

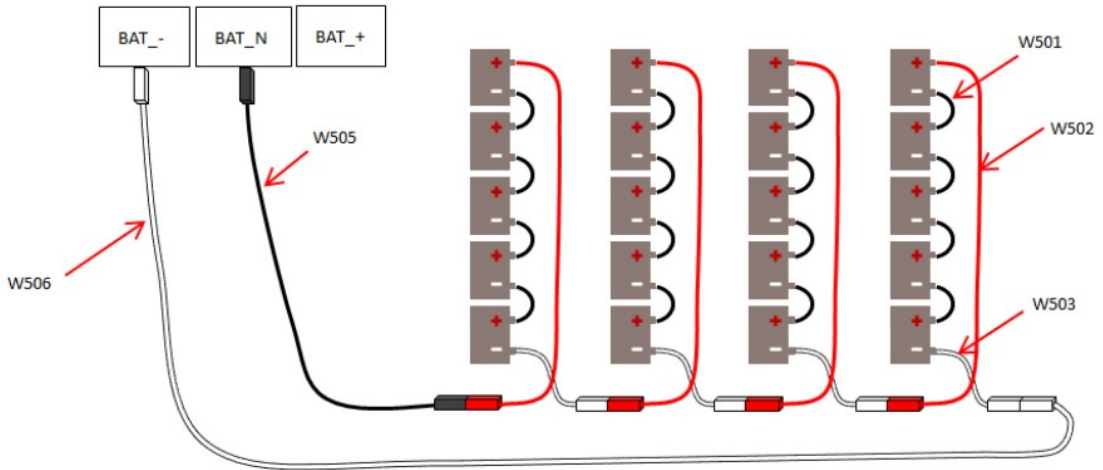

Cable connection of Layer 4

After the connection, connect the connectors as following as zoomed below.

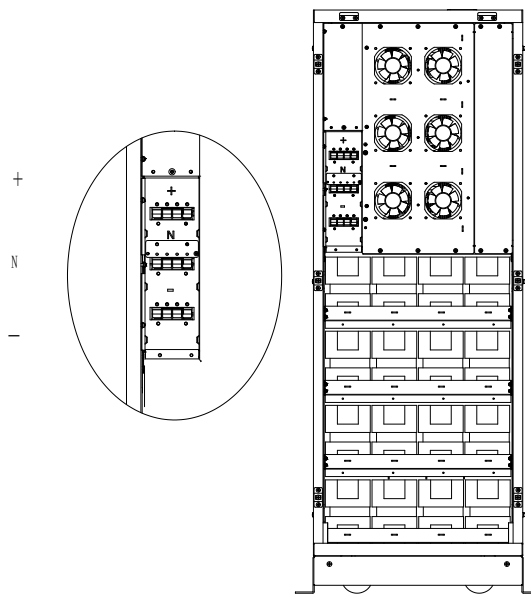

Battery terminal connection

After connecting the terminal, recover the cover as shown below.

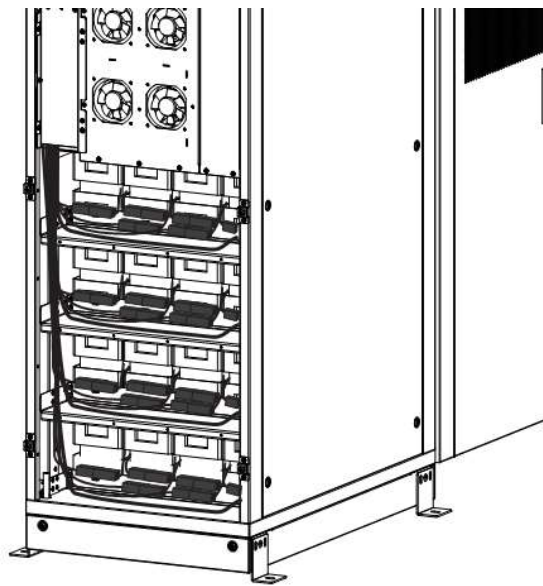

Recover the cover

 **Warning**

**Make sure the polarity of the battery is correct according to the diagrams above.
Test and confirm the battery voltage before connecting to the main circuit.**

Recycling information in accordance with the WEEE

The product is marked with the wheelie bin symbol. It indicates that at the end of life the product should enter the recycling system.

You should dispose of it separately at an appropriate collection point and not place it in the normal waste stream.

The figure below shows the wheelie bin symbol indicating separate collection for electrical and electronic equipment (EEE).

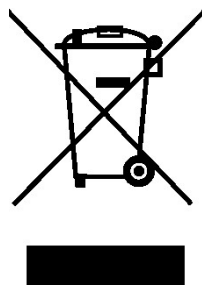

The Horizontal bar underneath the crossed-out wheelie bin indicates that the equipment has been manufactured after the Directive came into force in 2005.

The main parts of the drive can be recycled to preserve natural resources and energy. Product parts and materials should be dismantled and separated.

Contact your local distributor for further information on environmental aspects. End of life treatment must follow international and national regulations.