

U P S

On Line

1000VA - 3000VA

■ USER'S MANUAL ■

EMC Statements

These products have been tested and thereby comply with the condition of a Class C1 (1000VA) and Class C2 (2000VA and 3000VA), which has been established for offering sufficient protection against dangerous interference for installation in a residential area. Installation and use of the equipment should comply with the instructions provided in order to avoid such interference due to the amount of radio frequency energy that is radiated and generated by the equipment. In spite of this, we cannot assure that a certain amount of interference may not occur in some installations.

If, by turning on and off, it can be deduced that your radio or television reception is found to be influenced by harmful interference from the equipment, it is recommended to use one of the following preventive measures:

- Place the receiving antenna in a separate location or orientation.
- Ensure a greater distance is achieved between the receiver and the equipment.
- Ensure that your equipment is connected to an outlet on a separate circuit than the receiver.
- Contact a technician experienced with radio and TV or a dealer for further assistance.

Declaration of Conformity Request

Units labeled with a CE mark comply with the following standards and instructions:

- Safety: EN 62040-1
- EMC: EN 62040-2
- EMC Directive: 2014 / 30 / EU
- LVD Directive: 2014 / 35 / EU

The EC Declaration of Conformity is available upon request for products with CE mark.

CONTENT

IMPORTANT SAFETY INSTRUCTIONS	1
1. Introduction.....	2
2. System Description.....	2
3. Storage.....	2
4. Installation	3
4.1 Unpacking Package	3
4.2 Hardware Installation.....	4
4.3 Environment	4
4.4 Rear panel view.....	2
4.5 Connection to batteries.....	4
4.6 Connection to mains and loads	4
5. UPS Monitoring Connection	5
5.1 Connect UPS to Computer with USB / RS232 port	5
5.2 Connect UPS with RS232 port	5
5.3 Connect UPS with interface slot (Optional).....	5
5.4 EPO port (Emergency Power Off) (Optional)	5
6. Operations.....	6
6.1 General description	6
6.2 System Configuration.....	7
6.3 LCD panel overview	8
6.4 LCD control panel	9
6.5 UPS status display.....	10
6.6 UPS configurations	11
7. Battery Maintenance.....	12
7.1 Internal Battery replacement (For Rack Mounting Model)	12
7.2 External Battery Pack	12
8. Trouble Shooting.....	13
8.1 Trouble shooting (Error code)	13
9. Technical Specifications	14

IMPORTANT SAFETY INSTRUCTIONS

SAVE THESE INSTRUCTIONS

- **WARNING (SAVE THESE INSTRUCTIONS):** This manual contains important instructions that should be followed during installation and maintenance of the UPS and batteries. The equipment can be operated by any individuals with no previous experience.
- **WARNING:** It is highly recommended to install the product in a controlled environment; maximum ambient temperature is 40°C.
- **CAUTION:** Risk of electric shock – Please refer to the details on the cautionary markings at top, or rear, or bottom of UPS.
- **CAUTION:** Risk of electric shock – Heat-sinks are live. Disconnect unit before servicing.
- **CAUTION (UPS has internal batteries):** Risk of electric shock – Hazardous live parts inside this unit is energized from the battery supply even when the input AC power is disconnected.
- **CAUTION (No user serviceable parts):** Risk of electric shock – do not remove cover, no user serviceable parts inside. Refer service to qualified service personnel.
- **CAUTION (Non-isolated battery supply):** Risk of electric shock – battery circuit is not isolated from AC input. Hazardous voltage may exist between battery terminals and ground. Test before touching.
- **WARNING (Fuses):** To reduce risk of fire, replace only with the same type and rating of fuse.
- **CAUTION:** Do not disconnect battery connector under load.
- **ATTENTION:** Hazardous through electrical shock. Also with disconnection of this unit from the mains, hazardous voltage still may be accessible through supply from the batteries. The battery supply should therefore be disconnected in the positive and the negative pole when maintenance or service work inside the battery cabinet or UPS is considered.
- **CAUTION (For any pluggable only):** With the installation of this equipment it should be prevented, that the sum of the leakage current of the UPS and connected consumer does not exceed 3.5 mA.
- **CAUTION (For permanent connection only):** HIGH LEAKAGE CURRENT, Earth connection essential before connection supply.
- **CAUTION:** Do not dispose of batteries to fire, the battery may explode.
- **CAUTION:** Do not open or mutilate the battery, released electrolyte is harmful to human skin, eyes, etc.
- **CAUTION:** A battery can bring risk of electric shock and high short circuit current. The following precaution should be observed when working on batteries:
 - A. Remove watches, rings or other metal objects.
 - B. Use only tools with insulated handles.
 - C. Wear rubber gloves and boots.
 - D. Do not lay tools or metal parts on top of batteries.
 - E. Disconnect charging source prior to connecting or disconnecting battery terminals.To reduce risk of electric shock, disconnect the UPS from the mains supply before installing a computer interface signal cable. Reconnect the power cord only after signaling interconnections have been made.
- Servicing of batteries should be performed or supervised by personnel with knowledge of batteries and the required precautions. Keep unauthorized personnel away from batteries.
- **CAUTION:** When replacing batteries, replace with the same type and number of batteries: **One Sealed lead acid battery, rated 12 V, 9 AH max.**
- **CAUTION:** To reduce risk of fire, use only No.26 AWG or larger telecommunication line cable.
- **CAUTION:** Do not apply for uses in a computer room as defined in the Standard for the Protection of Electronic Computer \ Data Processing Equipment, ANSI/NFPA75.
- **CAUTION:** This UPS is not applicable for motors, hair dryers, speakers, and fluorescent lamps.
- **User's operations:**
 - The only operations that users are permitted to do are:
 - Turning the UPS unit on and off.
 - Operating the users interface.
 - Connecting data interface cables.
 - Changing the batteries.

All such operations are to be performed exactly as instructed in this manual. The greatest care possible must be taken for any of these operations and any change thereof may prove very hazardous to the operator.

The instructions contained within this safety manual are deemed important and should be closely followed at all times during installation and follow-up maintenance of the UPS and batteries.



CAUTION

The unit has a dangerous amount of voltage. If the UPS indicator is on, the unit's outlets may have a dangerous amount of voltage even when not plugged into the wall outlet because the battery may continue to supply power.

Cares should be taken to undertake installation indoors free from electrically-conductive particles which is under temperature and humidity control in order to reduce the risk of electric shock. It is best to disconnect the device using the power supply cord. Ensure that the equipment is placed in a position near the outlet where easily accessible. Except replacing the batteries, all service on this equipment must be carried out by qualified service personnel. Before conducting any maintenance, repair or shipment, first ensure that everything is turned off completely and disconnected.

1. Introduction

The information provided in this manual covers on-line single phase 1KVA to 3VA UPS (Uninterruptible Power System). This manual is about the basic functions, operating procedures, emergency troubleshooting, and also including the information about on how to ship, store, handle and install the equipment. Only detailed requirements of the UPS units are described herein, and installation must be carried out in accordance with this manual. Electrical installations must also carefully follow local legislation and regulations. Only qualified personnel should conduct these installations as failure to acknowledge electrical hazards could prove to be fatal.

2. System Description

Several different kinds of sensitive electrical equipment stay protected by a UPS (Uninterruptible Power System) including computers, workstations, process control systems, telecommunications systems, sales terminals, other critical instrumentation, etc. The purpose of the UPS is to protect these systems from poor utility power quality, complete loss of power, or other associated problems.

Electrical interference abounds in many forms causing problems in AC power, from lightning, power company accidents and radio transmissions to motors, air conditioners, and vending machines, among others. So protection of sensitive electrical equipment is vital to protect against power outages, low or high voltage, slow voltage fluctuations, frequency variations, differential and common-mode noises, transients, etc.

In order to prevent power line problems reaching critical systems causing damage to software, hardware and causing equipment to malfunction, the UPS helps by maintaining constant voltage, isolating critical load output if needed, and provides clean utility AC power.

3. Storage

Please adhere to the following instructions if the UPS is not installed immediately:

- Store the equipment as is in its original packing and shipping carton.
- Do not store in temperatures outside the range of +15°C to +25°C.
- Ensure that the equipment is fully protected from wet or damp areas and from moist air.

In order to maintain the vitality of the batteries, ensure that the UPS is recharged every 6 months for at least 8 hours.

Storage and Transportation

Please handle the unit with extreme caution since a high amount of energy is contained with the batteries. Always keep the unit in position as marked on the packaging and never drop the unit.

4. Installation

4.1 Unpacking Package

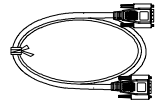
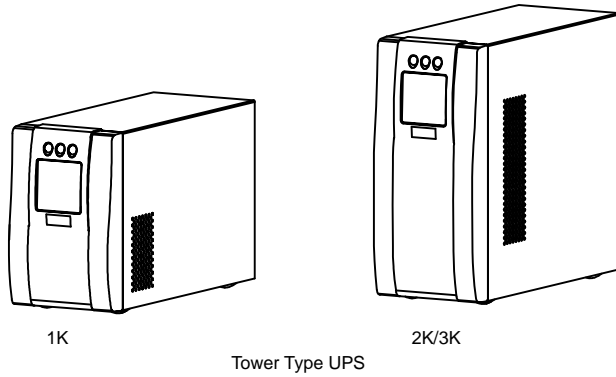

RS232 Cable

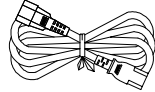

POWER Cord

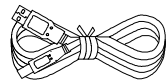

USB Cable

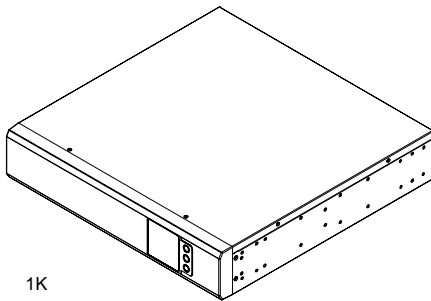

1K

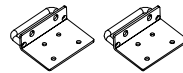

Rack Mounting Ears (2)



M5X8L(8) Screw

(Rack Model Only)



Rack Tower Stand (4)



M5X8L(8) Screw

(Rack Model Only)

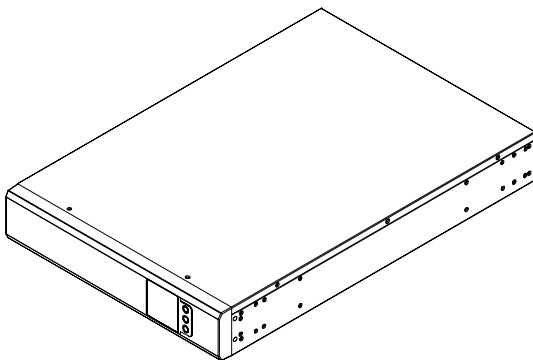

2K/3K

Rack Type UPS

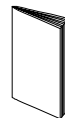

User's Manual



Power Management Software (Option)

1K or 2K/3K Tower/Rack Type UPS

4.2 Hardware Installation

Rack Tower Stands Installation

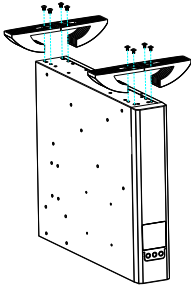

Attach four rack tower stands to UPS, using provided M5 screws *8pcs.

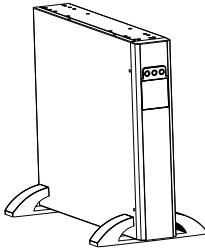

The demonstrations of UPS tighten up with rack tower stands.

Rack Mounting Ears Installation

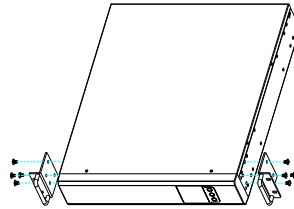

Attach two rack mounting ears to UPS, using provided M5 screws *8pcs.

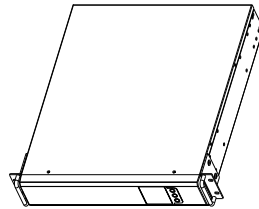

The demonstrations of UPS tighten up with rack mounting ears.

4.3 Environment



Please follow below instructions about locating the UPS system and battery option or the safety of installation personnel cannot be guaranteed and the unit may malfunction.

- Please ensure no flammable substances such as gases or fumes are present.
- Avoid extreme temperature and humidity. Protect the equipment from moisture.
- Ensure there are enough space at the behind and side of UPS for well ventilation.
- Ensure that the front of the UPS remains clear for user operation.
- Battery lifecycle could be extended with recommended temperature range of 15 °C to 25 °C.
- It is highly recommended that The External Battery Packs are next to or under the UPS.
- Only a technician from the manufacturer or an authorized agent may service the unit.
- Do not open UPS cabinet as the components may contain high voltage and may be fatal.
- The output receptacles may carry live voltage even when it is not connected to power supply.

4.4 Rear panel view

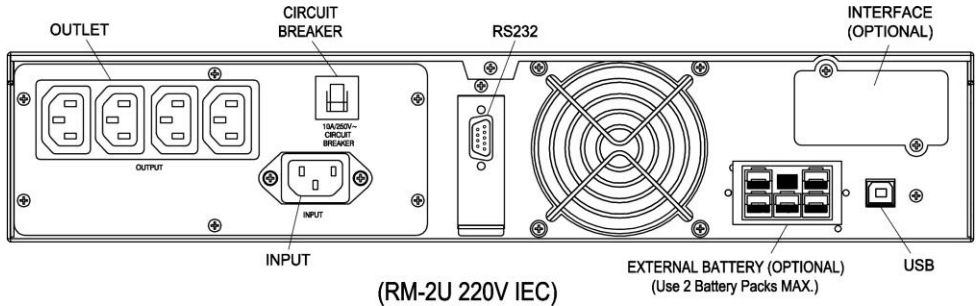

1KVA

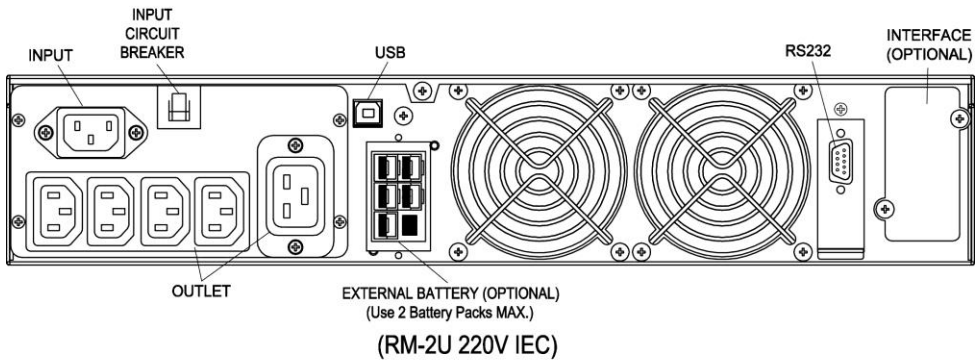

2KVA

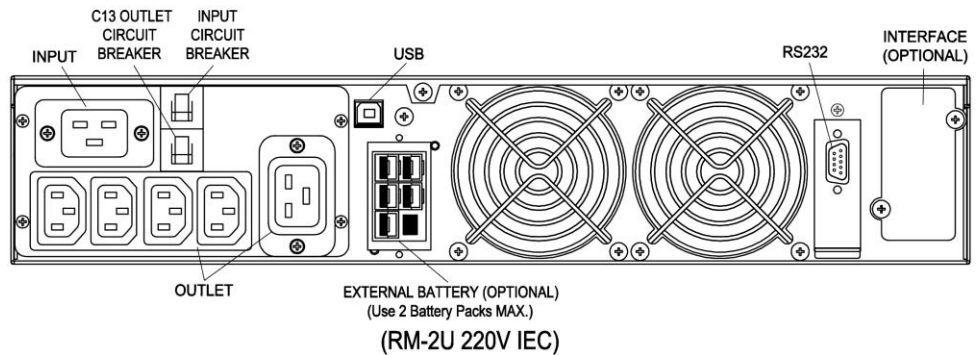

3KVA

Fig.2 Rear panel of UPS 1KVA to 3KVA (Rack Type)

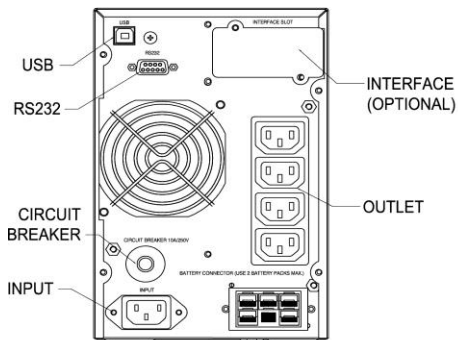

(220V IEC)-1000

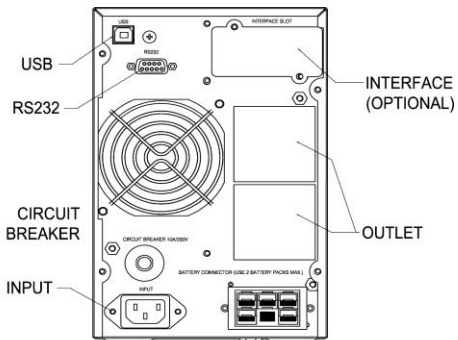

(220V E/F/G/I TYPE)-1000

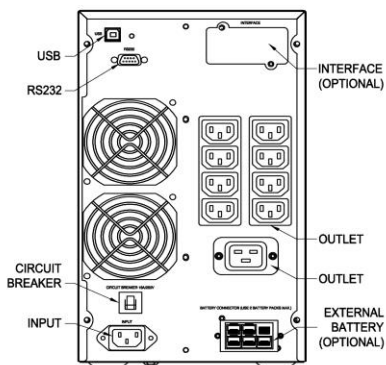

(220V IEC)-2000

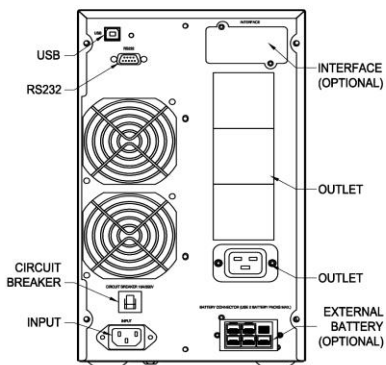

(220V E/F/G/I TYPE)-2000

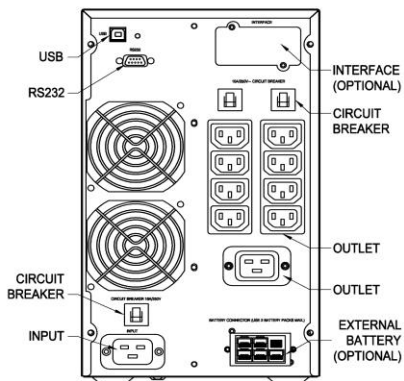

(220V IEC)-3000

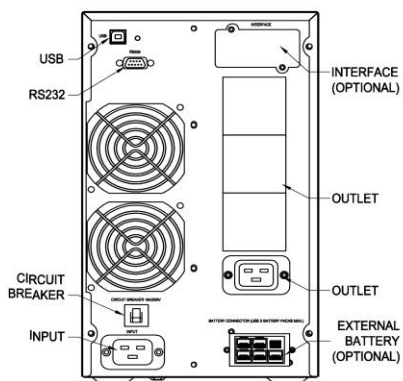

(220V E/F/G/I TYPE)-3000

Fig.3 Rear panel of UPS 1KVA to 3KVA (Tower Type)

4.5 Connection to batteries

Please follow below instructions for battery connections:

- External Battery Packs shall be installed by SERVICE PERSONNEL only.
- Ensure that the UPS is disconnected from mains and loads while connecting the External Battery Pack.
- Use the battery cable that comes with the External Battery Pack to connect the External Battery Pack to the UPS.
- Connect a second battery cabinet to the first one with the cable provided if more than one is to be installed.
- This UPS may be provided with maximum two extension battery packs. (for UL Approval)

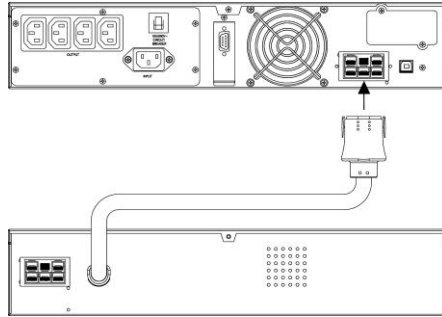

Fig.4 Example of connecting to external battery pack

4.6 Connection to mains and loads

- The following input and output cables come supplied with all models
 - For 1000VA model, IEC 320 10 A (Input cable)
 - For 2000VA model, IEC 320 10 A (Input cable)
 - For 3000VA model, IEC 320 16 A (Input cable)
- Connect the input cable to the UPS and connect the other end to a grounded outlet. The batteries will automatically charge when connected to the mains. Please realize that although you may start using the UPS immediately, maximum back-up time will still not be available, so it is recommended to charge the batteries for a minimum of 8 hours before use.
- If unit instantly shows “Error 06” for Site Wiring Fault, please rotate the connector (Schuko)
- After charging, connect the loads to the UPS (see the example in fig 3).
- Do not connect any devices that have the possibility of overloading the UPS or drawing half-wave rectified current, such as hair dryers or vacuum cleaners.
- Should computer or alarm connections be used, use connections according to chapter 5 of the manual provided with that option. The connections can be referred to on the rear panel.
- The installation is now complete.

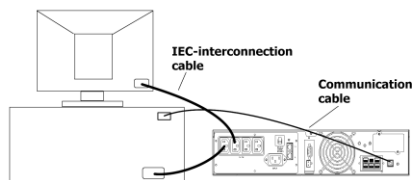

Fig.5 Example of Installation of Plug & Play products

5. UPS Monitoring Connection

To monitor the UPS status and perform some simple UPS self-test, it is required to connect the UPS to the computer or the internet.

5.1 Connect UPS to Computer with USB / RS232 port

- Refer to [Chapter 4.4](#), find the USB / RS232 port at the rear of UPS.
- Connect UPS and Computer with the communication cable provided with UPS.
- Make sure the computer supports the power management software and install the power management software in the Computer.

!!Notice!! Either USB port or RS232 port, only one port will function at a time.

5.2 Connect UPS with RS232 port

- The RS-232 interface uses a 9-pin female D-sub connector.
- The RS-232 port carries the data about utility, load and the UPS.
- The interface port pins and their functions are identified in the following table.

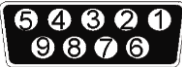

Pin #	Signal	Direction	Function
2	TxD	Output	TxD Output
3	RxD	Input	RxD / Inverter Off Input
5	Common		Common
6		Output	AC Fail Output
8		Output	Low Battery Output
9		Output	12VDC Power

Caution! Max rated values 12VDC

5.3 Connect UPS with interface slot (Option)

- **SNMP card** allows UPS management and monitoring over a network or internet.
- **AS400 card** allows voltage free relay contacts.
- For more information, please contact for technical assistance.

5.4 EPO port (Emergency Power Off) (Option)

A customer-supplied switch located remotely can be used to open the EPO connection and allows UPS output receptacles to be switched off. Since the EPO shuts down the equipment immediately, orderly shutdown procedures are not followed and not by any power management software. The UPS will have to be manually restarted in order to regain power to the outlets.

6. Operations

6.1 General description

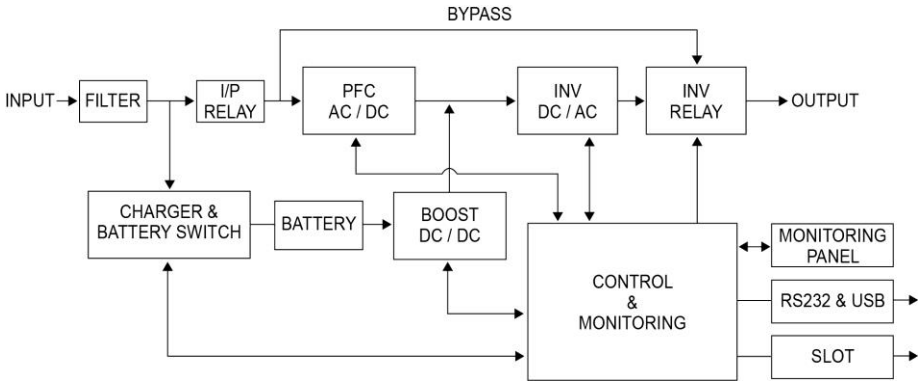

Fig.6 Block diagram

Line Mode / Battery Mode

As a double conversion on-line UPS, it is necessary to supply uninterrupted, clean single-phase power to your critical systems. The diagram of the UPS is as shown in Fig.6.

- Input filter reduces transients on the mains.
- With PFC AC/DC, the AC-power is rectified and regulated to DC power.
- DC power is converted to AC in the inverter passing it on to the load.
- Power will be maintained from the battery during the AC power failure. (**Battery Mode**)

Free Run Mode

Free Run Mode provides UPS a wider input frequency range. While Line mode provides the same frequency as AC power when AC power frequency is within the selected range (user selectable with software), Free Run Mode enlarge the range up to 45Hz to 65Hz but fix the output frequency as 50Hz for 220V system and 60Hz for 110V system with $\pm 0.25\text{Hz}$. Free Run Mode is recommended if the AC power has large variation.

Free Run Mode is activated in default and can run with line mode at the same time.

High Efficiency Mode

The Efficiency Optimizer Function is a new feature for the UPS adding cost effectiveness, minimizing power loss and reducing power consumption. Alternating between bypass and on-line modes is achieved automatically and in accordance with the conditions of the utility power. On-line mode may be used during times of intermittent power supply, and bypass mode when power flows smoothly in order to obtain greatest efficiency. Irregularities can be detected in less than a second, and on-line mode reactivated immediately. Switching back to online mode occurs when input voltage is outside $\pm 10\%$ or nominal ($\pm 15\%$ selectable), when input frequency is outside of $\pm 3\text{Hz}$ or when no input line is available.

High Efficiency Mode can be activated from the LCD panel. Please refer to [Chapter 6.6](#).

Generator Mode

Generator Mode is specially designed function while input AC power is very unstable. While Generator Mode, UPS will never switch to bypass to prevent damage to the load and UPS will fix the output frequency as 50Hz for 220V system and 60Hz for 110V system with $\pm 0.25\text{Hz}$. Generator Mode can also protect batteries from discharging too frequently. Generator Mode can be activated from the LCD panel. Please refer to [Chapter 6.6](#).

Battery Test

A diagnostic test is automatically executed when UPS start up and checks UPS electronics, battery, and reports any problems on the LCD display. While advanced battery management system always monitors the conditions of the batteries, it sends early warnings if battery replacement is needed.

The default is to perform a battery discharge test every 30 days of normal mode operation. Diagnostic tests can be performed manually from the front panel at any time.

6.2 System Configuration

The UPS device and the internal backup battery make up the system. Depending on the site and load requirements of the installation, certain additional options are available as a tailored solution.

The following items should be taken into consideration when planning a UPS system:

- The total demand of the protected system shall dictate the output power rating (VA). Allowing a margin for future expansion or calculation inaccuracies from measuring power requirements.
- Backup time needed defines the battery size needed. If load is less than the UPS nominal power rating then actual backup time is longer.

The following options are available:

- ◆ External Battery Packs
- ◆ Transformer cabinets
- ◆ Maintenance bypass switches
- ◆ Connectivity options (relay card, SNMP/WEB card)

Typical UPS internal battery backup time:

Model		Backup time for 100% load with internal batteries	Recharge time to 90% capacity
Tower Type	1000VA	1.5 - 2 min	4 hours
	2000VA	3 - 5 min	4 hours
	3000VA	2 - 4 min	4 hours
Rack Mounting Type	1000VA	3 - 5 min	4 hours
	2000VA	3 - 5 min	4 hours
	3000VA	2 - 4 min	4 hours

Additional External Battery Pack is available if more back-up time is needed.

6.3 LCD panel overview

Operation of the UPS is indicated on the monitor panel with a LCD screen. This display is also capable of alerting the user with audible alarms. Status of the UPS, measurements and alarms are all indicated on the LCD screen.

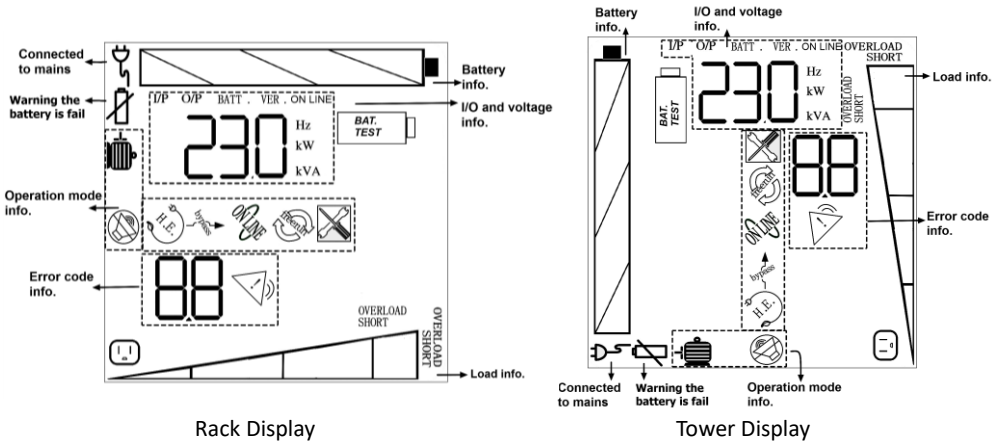

Fig.6 LCD display

Display	Function Description	Display	Function Description
	Connected to Mains		System Normal
	Battery Remaining 0-24%, 25-49%, 50-74%, 75-100%		Free Run Mode
	Battery Test		Manual Bypass Mode (MAINTENANCE ONLY)
	Battery Fail		Fault Occurs
	Generator Mode	OVERLOAD	UPS Overload
	Silence Mode	SHORT	Output Short
	High Efficiency Mode		Output Working Normally
	Bypass		Load level by 0-24%, 25-49%, 50-74%, 75-100%

6.4 LCD control panel

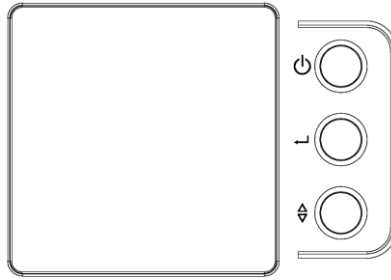







Fig.7 Control panel

: ON/OFF

- Press “  ” button and hold for 3 seconds to turn on the UPS.
- While UPS is working, press “  ” button and hold for 3 seconds to turn off the UPS.







: Status or Enter

There are **10** status can be configured by user.

- To check the “**Status**” of UPS, release the “  ” button after holding it for 1 second.
- Keep pressing “  ” button to see the other status
- “**Enter**” function will only be activated while settings. See more in the “  ” button.
- If UPS idles more than 20 seconds, the display will return to main status.



: Settings or Selection

There are **7** status can be configured by user.

- To change the “Settings”, release the “  ” button after holding it for 1 second to enter the configurations mode of the UPS.
- Keep pressing “  ” button to see other configurations.
- After choosing the function, press “  ” button to enter the function.
- Press “  ” button to select your options.
- Press “  ” button to enable your option.
- Press “  ” button again to confirm and enable your function.
- If UPS is idle over 10 seconds, the display will return to main status.

Start up the UPS

Notice!! Start up the UPS with AC power at the first time to unlock the factory DC lock setting.

- Make sure the installation is correct and the input power cable is connected to a well-grounded outlet.
- Press “” button and hold for 3 seconds to turn on the UPS.
- The UPS should now start its inspection of: internal functions, main synchronization and inverter startup. Then power should start to be supplied via the outlets.
- The LCD shall light up when output power has commenced and the LCD will display “”.
- Switch on the loads.

Shut down the UPS

- Shut down and turn off all the loads.
- Press “” button and hold for 3 seconds. UPS will shut down after a long beep.
- When emergency occurs, EPO (optional) is located at the rear of UPS. Pull off to force shutdown the UPS immediately.

6.5 UPS status display

UPS status will display as following meter, press “” to show all UPS status.

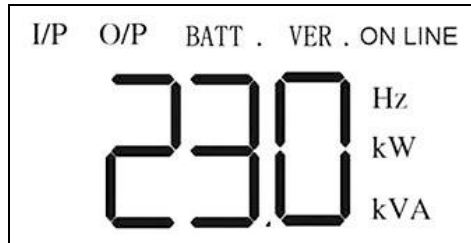

LCD message	Description
O/P x x x V	Shows Output AC Voltage
O/P x x.x Hz	Shows Output Frequency
I/P x x x V	Shows Input AC Voltage
I/P x x.x Hz	Shows Input Frequency
BATT. x x.x V	Shows Battery Voltage
O/P x x x W	Shows Output Capacity (Watts)
O/P x x x VA	Shows Output Capacity (VA)
O/P x x A	Shows Output Current
VER. x kVA	Shows UPS Rating
VER. x.x.x --	Shows UPS Firmware Version

6.6 UPS configurations

Notice!! The factory default settings do not necessarily have to be changed, although you are free to tailor the UPS as your specific needs.

To enter the configuration mode, release “” button after holding it for 1 second;

The first configuration will be shown on the LCD display.

Press the “” button to switch through the parameters;

Press the “” button to select the parameter;









Press the “” button to switch through the options for the selected parameter;

Press the “” button to select yes/no to confirm;

Press the “” button to enable your selection, your selection will start automatically.

If UPS is idle over 10 seconds, the display will return to main status.

Notice!! Manual Bypass should always set to OFF for UPS and power management software to operate normally. This is aimed for operating an external maintenance bypass switch.

Function Setting	Icon	Available Setting	Default Setting
Setting		--	--
Output Voltage		[208V][220V][230V][240V]	[220V]
Perform Battery Test		[On][Off]	[Off]
Manual Bypass		[On][Off]	[Off]
Free Run Mode		[On][Off]	[On]
High Efficiency Mode		[On][Off]	[Off]
Silence		[On][Off]	[Off]
Generator Mode		[On][Off]	[Off]

7. Battery Maintenance

7.1 Internal Battery replacement (For Rack Mounting Model)

The following is a step by step tutorial for replacing the internal battery:

1. Remove the front panel

The front panel of UPS can be removed by pulling one side of the front panel as the picture shows on the left:

2. Unscrew the screw and remove the metal baffle plate.

3. Disconnect the battery wires and pull out the battery box.

!!DO NOT DISCONNECT the batteries while UPS is in Battery mode!!

4. Replace the batteries with the same number and type as originally installed.

5. Replace the battery and push the battery box back into the UPS.

6. Reinstall the metal baffle plate and the front panel.

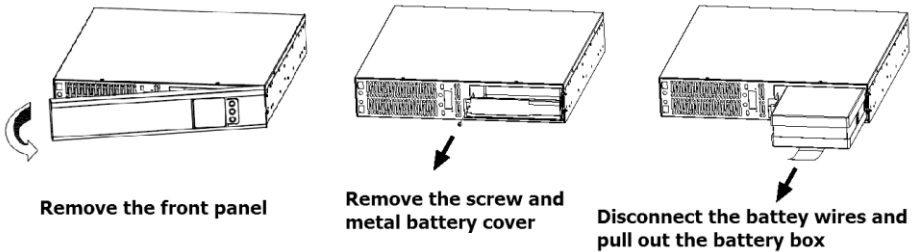

Fig.8 Replacing battery



Batteries may cause electrical shock or burn from high short circuit currents. Please observe the following precautions:

1. Remove jewelry and metal objects such as watches and rings.
2. Use tools that have insulated handles.
3. Keep tools and other metal objects from contacting and away from the batteries.

ELECTRIC ENERGY HAZARD: Do not attempt to rewire, alter, or change any battery wiring or connectors. Attempting to make such alterations can cause injury.

7.2 External Battery Pack

Notice!! When power is supplied by external batteries, output toward loads must be limited to less than 90% of overall power generation."

Battery Cabinets

Model		1000	2000	3000
Battery Type		12V 7Ah		12V 9Ah 12V 7Ah (Option)
Number of Batteries		6	12	12
Backup time /Full load (min) (Battery Pack)		Approx. 13-15	Approx. 13-15	Approx. 10-13
Typical Recharge time		<8 hrs to 90%		
Energy Saving		Yes - ECO Mode Efficiency >94%		
Dimensions WxDxH (mm)	Tower Type	152 x 420 x 237	225 x 420 x 360	
	Rack Type	428 x 425 x 84	428 x 635 x 84	
Net Weight (kgs)	Tower Type	20	35	41 (9AH battery)
	Rack Type	21	43.5	49.5 (9AH battery)

Specifications are for reference, actual information should base on real product.

8. Trouble Shooting

Silencing Alarm

This is a special design for Silence during **Battery Mode**. By pressing any of the three buttons on the front panel, UPS will mute during Battery Mode. When the battery runs low, UPS will alarm again to draw attention.

On the LCD display, you can also choose silent mode which will not warn you of any malfunction audibly.

General Maintenance

With a minimal amount of maintenance, you can expect the UPS to function smoothly. Otherwise consider changing the batteries to have a longer life free of trouble.

The most critical issues for the reliability of the UPS are environmental issues.

Ensure that the temperature and humidity always match the specifications and keep the area around the UPS clean and dust free.

At a temperature of 25°C, the typical battery lifetime is 2 year.

Check every 6 to 12 months whether the back-up time of the battery is adequate.

8.1 Trouble shooting (Error code)

Situation	No.	Alarm	Description & Solution
High Output voltage	01	Constant Beep	<u>High output voltage</u> Contact for technical assistance
Low Output voltage	02	Constant Beep	<u>Low output voltage</u> Contact for technical assistance
Output short	03	Constant Beep	<u>Output short circuit</u> Contact for technical assistance
Bus fault	04	2 Beep per second	<u>High internal DC bus Voltage</u> Contact for technical assistance
Over temperature	05	Constant Beep	<u>High Surrounding Temperature.</u> Make sure the unit's fans and vent holes are not blocked. If these conditions did not solve the problem, call your service representative.
Site wiring fault	06	1 Beep per second	<u>Wrong UPS input wiring between Neutral and Line</u> Wrong connection of UPS input and main. Turn the plug 180 and plug in again.
Output overload	07	2 Beeps per second	<u>Connected equipment needs more power than UPS can provide. Line Mode UPS is overload, UPS is in bypass</u> Shut off the least important equipment connected to UPS. UPS will switch from bypass back to normal operation if the overload problem is solved.
Over charge	08	Constant Beep	<u>Batteries are overcharge</u> Turn off protected loads. Turn off UPS and call your local dealer
Charger failure	09	No beep	<u>Charger has failed</u> Contact for technical assistance
Battery failure	10	3 Beep every 5 seconds	<u>Battery has failed</u> Contact for technical assistance
Line abnormal	11	1 Beep per second	<u>Wrong AC Line backed up during auto restart</u> Check main power and frequency
Battery test	--	No beep	<u>The UPS is doing a battery test</u> No action needed. UPS will return to normal operation when it completes the battery test successfully.
Battery mode	--	1 Beep every 5 seconds	<u>The unit is operating on Battery Power</u> Save your data and perform a controlled shutdown.
Low battery	--	2 Beep every 5 seconds	<u>UPS will shut down due to low battery voltage</u> The unit will restart Automatically when acceptable power returns.

9. Technical Specifications

Tower Type

Model	1000	2000	3000
Configuration			
Capacity (VA)	1000 VA	2000 VA	3000 VA
Capacity (Watts)	1000 W	2000 W	3000 W
Form	Tower Type		
Phase	Single Phase		
Energy Saving	Yes - ECO Mode Efficiency >94%		
Input			
Voltage	208 / 220 / 230 / 240 Vac		
Input Voltage Range	120 - 276 VAC, < 25% Load		
	140 - 276 VAC, < 50% Load		
	160 - 276 VAC, < 75% Load		
	180 - 276 VAC, < 100% Load		
Input Frequency Range	50 / 60 Hz (Auto Sensing)		
Input Power Factor	>0.97		
Cold Start	Yes		
Output			
Rated Power Factor	1.0		
Waveform	Pure Sine Wave		
Voltage	208* / 220 / 230 / 240 Vac ± 2%		
Frequency	50 / 60 Hz ±0.25 Hz		
Transfer Time	0 ms		
Harmonic Distortion	≤ 2.5% THD at Linear Load		
Crest Factor	3 : 1		
EPO Function	Option		
Protection			
Overload	Line Mode	105% - 120% for 30 seconds	
		121% - 150% for 10 seconds	
	Battery Mode	101% - 109% for 10 seconds	
		110% - 120% for 3 seconds	
Surge Protection	IEC 61000-4-5 Level 3		
Bypass	Internal Bypass (Automatic and Manual)		
Short Circuit Protection	UPS Output Cut Off Immediately		
Battery			
Bypass	Internal Bypass (Automatic and Manual)		
Short Circuit Protection	UPS Output Cut Off Immediately		
Type	12V 9Ah	12V 7Ah	12V 9Ah
Quantity	2	6	6
Sealed, Maintenance Free	Yes		
Typical Recharge Time	4 hr to 90%		
External Battery Module	Option		
External Battery Connector	Option		
Management & Communication			
Indicator	LCD Control Panel		
Communication Port	RS 232, USB B type		
SNMP Slot	Option		
Audible Alarms	Yes		
Physical			
Dimensions(WxDxH)(mm)	144 x 357 x 228	191 x 406 x 327	191 x 406 x 327
Weight (kgs)	10.4	20.3	22.9
Shipping Dimensions(mm)	249 x 448 x 359	292 x 500 x 455	292 x 500 x 455
Shipping Weight (kgs)	11.5	22.3	24.9

* While 208V output, capacity will be derated to 90%.

** Specifications are subject to change without further notice.

** Specifications are for reference, actual information should be based on real product.

Rack Mounting Type

Model	1000	2000	3000
Configuration			
Capacity (VA)	1000 VA	2000 VA	3000 VA
Capacity (Watts)	1000 W	2000 W	3000 W
Form	Rack and Tower Type		
Phase	Single Phase		
Energy Saving	Yes - ECO Mode Efficiency >94%		
Input			
Voltage	208 / 220 / 230 / 240 Vac		
Input Voltage Range	120 - 276 VAC, < 25% Load 140 - 276 VAC, < 50% Load 160 - 276 VAC, < 75% Load 180 - 276 VAC, < 100% Load		
Input Frequency Range	50 / 60 Hz (Auto Sensing)		
Input Power Factor	>0.97		
Cold Start	Yes		
Output			
Rated Power Factor	1.0		
Waveform	Pure Sine Wave		
Voltage	208* / 220 / 230 / 240 Vac ± 2%		
Frequency	50 / 60 Hz ±0.25 Hz		
Transfer Time	0 ms		
Harmonic Distortion	≤ 2.5% THD at Linear Load		
Crest Factor	3 : 1		
EPO Function	Option		
Protection			
Overload	Line Mode	105% - 120% for 30 seconds	
	Battery Mode	101% - 109% for 10 seconds	
Surge Protection	IEC 61000-4-5 Level 3		
Bypass	Internal Bypass (Automatic and Manual)		
Short Circuit Protection	UPS Output Cut Off Immediately		
Battery			
Type	12V 7Ah	12V 7Ah	12V 9Ah
Quantity	3	6	6
Sealed, Maintenance Free	Yes		
Typical Recharge Time	4 hr to 90%		
External Battery Module	Option		
External Battery Connector	Option		
Management & Communication			
LCD Control Panel	Yes		
Communication Port	RS 232, USB B type		
SNMP Slot	Option		
Audible Alarms	Yes		
Physical			
Dimensions (WxDxH) (mm)	428x425x84	428x635x84	
Weight (kgs)	14.7	26.2	29
Shipping Dimensions (mm)	546x552x206	550x750x220	
Shipping Weight (kgs)	17.5	30	33.4

** Specifications are subject to change without further notice.

** Specifications are for reference, actual information should base on real product.

© All rights reserved. All trademarks are property of their respective owners. Specifications are subject to change without notification.